

## **TECHNICAL MANUAL**

### **Fire damper type mcr WIP PRO**

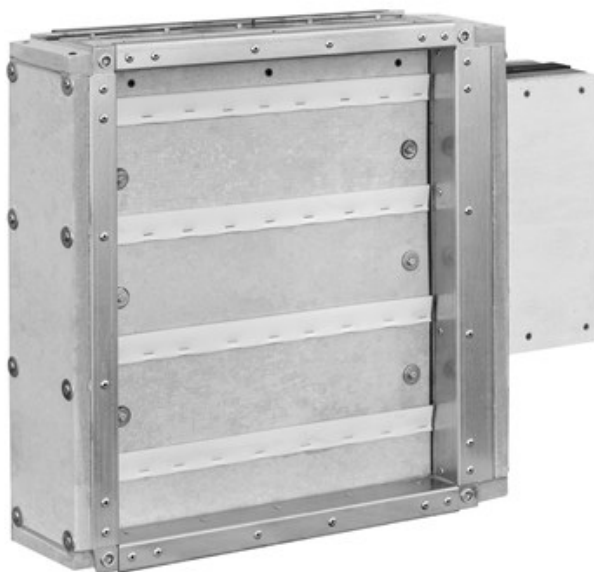

Version WIP PRO 20.08.19.13

## CONTENTS:

1. INTRODUCTION .....	3
2. SUBJECT .....	3
3. INTENDED USE .....	3
4. DESIGN & OPERATING PRINCIPLE .....	4
5. DEVICE IDENTIFICATION .....	7
6. INSTALLATION .....	7
6.1. PRE-ASSEMBLY INSPECTION .....	7
6.2. INSTALLATION OPENING .....	7
6.3. EMBEDDING .....	8
6.4. ELECTRICAL CONNECTIONS .....	15
7. TRANSPORT & STORAGE CONDITIONS .....	18
8. MAINTENANCE & SERVICING .....	18
9. WARRANTY TERMS & CONDITIONS .....	19

### Technical Manual designations

- Option available
- Option unavailable

# mcr WIP PRO multi-blade fire damper

## NOTE

All previous issues of this Technical Manual expire on the date of issue hereof.  
The Technical Manual does not apply to the fire dampers manufactured before its date of issue.

## 1. INTRODUCTION

The purpose of this Technical Manual is to present the intended use, design, principle of operation, correct installation and operation of the mcr WIP PRO multi-blade fire damper, intended for fire ventilation systems.  
The Manual also includes additional information about the operating and transport conditions, and warranty terms and conditions applicable to the product.

## 2. SUBJECT

This Manual concerns the entire group of multi-blade fire dampers type mcr WIP PRO. Compliance with the Manual guidelines ensures correct performance of the device in terms of fire protection of rooms as well as safety of the system users.

## 3. INTENDED USE

### Application

Type mcr WIP PRO multi-blade fire dampers may be used as:

- shut-off fire dampers – mcr WIP PRO/S
- shut-off fire dampers for fire ventilation systems – mcr WIP PRO/V
- shut-off fire dampers for mixed fire ventilation systems – mcr WIP PRO/V-M
- transfer fire dampers – mcr WIP PRO/T
- relief fire dampers – mcr WIP PRO/T-G

The dampers cannot be operated in systems exposed to dust, except for when they are included in a special, individually developed program of service and technical inspections.

### Fire resistance

Type mcr WIP PRO fire dampers have the following fire resistance ratings:

<input checked="" type="checkbox"/> EI60S	<input checked="" type="checkbox"/> /S	<input checked="" type="checkbox"/> /V	<input checked="" type="checkbox"/> /V-M	<input checked="" type="checkbox"/> /T	<input type="checkbox"/> /T-G	<input checked="" type="checkbox"/> EI120S	<input checked="" type="checkbox"/> /S	<input checked="" type="checkbox"/> /V	<input checked="" type="checkbox"/> /V-M	<input checked="" type="checkbox"/> /T	<input type="checkbox"/> /T-G
<input checked="" type="checkbox"/> EI60	<input checked="" type="checkbox"/> /S	<input checked="" type="checkbox"/> /V	<input checked="" type="checkbox"/> /V-M	<input checked="" type="checkbox"/> /T	<input type="checkbox"/> /T-G	<input checked="" type="checkbox"/> EI120	<input checked="" type="checkbox"/> /S	<input checked="" type="checkbox"/> /V	<input checked="" type="checkbox"/> /V-M	<input checked="" type="checkbox"/> /T	<input type="checkbox"/> /T-G
<input checked="" type="checkbox"/> E60S	<input checked="" type="checkbox"/> /S	<input checked="" type="checkbox"/> /V	<input checked="" type="checkbox"/> /V-M	<input checked="" type="checkbox"/> /T	<input type="checkbox"/> /T-G	<input checked="" type="checkbox"/> E120S	<input checked="" type="checkbox"/> /S	<input checked="" type="checkbox"/> /V	<input checked="" type="checkbox"/> /V-M	<input checked="" type="checkbox"/> /T	<input type="checkbox"/> /T-G
<input checked="" type="checkbox"/> E60	<input checked="" type="checkbox"/> /S	<input checked="" type="checkbox"/> /V	<input checked="" type="checkbox"/> /V-M	<input checked="" type="checkbox"/> /T	<input type="checkbox"/> /T-G	<input checked="" type="checkbox"/> E120	<input checked="" type="checkbox"/> /S	<input checked="" type="checkbox"/> /V	<input checked="" type="checkbox"/> /V-M	<input checked="" type="checkbox"/> /T	<input type="checkbox"/> /T-G
<input checked="" type="checkbox"/> EI180	<input type="checkbox"/> /S	<input type="checkbox"/> /V	<input type="checkbox"/> /V-M	<input checked="" type="checkbox"/> /T	<input type="checkbox"/> /T-G	<input checked="" type="checkbox"/> E180	<input type="checkbox"/> /S	<input type="checkbox"/> /V	<input type="checkbox"/> /V-M	<input checked="" type="checkbox"/> /T	<input type="checkbox"/> /T-G

The fire resistance rating depends on application, method and place of installation of the damper.

### Versions

Multi-blade fire damper mcr WIP PRO is manufactured in below showed versions:

- Rectangular dampers
- Rectangular dampers with round connections
- Round dampers

### Dimension type series

The mcr WIP PRO fire dampers are manufactured in the following size ranges:

Type	mcr WIP PRO /S mcr WIP PRO /V, mcr WIP PRO /V-M	mcr WIP PRO /T	mcr WIP PRO /V mcr WIP PRO /V-M
Width	from 110 to 900 mm	from 110 to 900 mm	from 260 to 1250 mm
Height	from 263 to 1250 mm	from 263 to 1250 mm	from 110 to 1250 mm
Length	135 mm		
Rotation axis	Horizontal	Horizontal/ vertical	Horizontal/ vertical
Max. surface area	1,125 m <sup>2</sup>	1,125 m <sup>2</sup>	1,56 m <sup>2</sup>
Min. surface are	0,029m <sup>2</sup>		

In addition to standard dimensions, it is possible to make flaps with intermediate dimensions. The availability of individual dimensions is described in the DoP of the device.

## 4. DESIGN AND OPERATING PRINCIPLE

---

### Design

---

The mcr WIP PRO multi-blade fire dampers comprise a casing with a rectangular cross-section (depending on the version). Construction of the WIP PRO consist of:

- Casing of the damper, made of galvanized or stainless steel sheet (2 sections divided with fire-retardant board), covered from outside with refractory board and C-shape profiles made of galvanized steel;
- whole casing is reinforced from both sides with corners made of flat steel;
- Damper blades rotating around its own axis. Axis is made from 2 steel pivots - each pivot is placed in a brazen sleeve fastened to the fire damper vertical side wall (H).
- An intumescent gasket and a ventilation gasket, fastened with staples, which is placed on entire length of damper blade
- Release mechanism (actuated by remote control or automatically after activation of the thermal release)
- Vertical side wall of damper with actuator secured with refractory board
- Intumescent and ventilation gaskets (inside of the casing – on the vertical damper side wall “H”)
- A steel shield of actuator in omega letter shape, installed on side “H” of the damper
- Limit profiles made of galvanized or stainless steel, which are restricting movement of the damper blade, placed inside of casing surface. Profiles are covered with ventilation seal.

### Operating principle

---

The operating principle and way of working of the mcr WIP PRO multi-blade fire dampers depend on their application versions:

#### ■ shut-off fire dampers – mcr WIP PRO/S

In the normal operating position the dampers are open. Closing of the dampers (to the safety position) follows:

- automatically, by tripping the thermoelectric trigger
- manually, by pressing the control button on the thermoelectric trigger
- remotely, by tripping an electric axial actuator with a return spring caused by isolation from the voltage supply
- automatically, by tripping the thermal trigger and the driving spring

#### ■ shut-off fire dampers for fire ventilation systems – mcr WIP PRO/V

In the normal operating position the dampers are closed. Opening of the dampers (to the safety position) follows:

- remotely, by tripping an electric axial actuator without a return spring, as a result of applying the supply voltage to the actuator in the right manner

#### ■ shut-off fire dampers for mixed fire ventilation systems – mcr WIP PRO/V-M

In normal operation the dampers are closed or open, depending on the function carried out. Opening / closing of the dampers (to the safety position) follows:

- remotely, by tripping an electric axial actuator without a return spring, as a result of applying the supply voltage to the actuator in the right manner

#### ■ transfer fire dampers – mcr WIP PRO/T

In the normal operating position, the dampers are open. Closing of the dampers (to the safety position) follows:

- automatically, by tripping the thermoelectric trigger
- manually, by pressing the control button on the thermoelectric trigger
- remotely, by tripping an electric axial actuator with a return spring caused by isolation from the supply voltage
- automatically, by tripping the thermal trigger and the driving spring

#### □ relief fire dampers – mcr WIP PRO/T-G

In the normal operating position, the dampers are open or closed, depending on the function carried out.

Opening / closing of the dampers (to the safety position) follows:

- remotely, by tripping an electric axial actuator with a return spring caused by isolation from the supply voltage. The actuator has no thermoelectric trigger.

Proper performance manual check of dampers with electrical actuator for maintenance purposes can be done by using a special hex wrench. The key should be placed in marked socket on the actuator. Thanks to the rotation of the key, damper blade can be placed in desired position. Rotate the wrench slowly, smoothly and carefully. Rotating the wrench too fast or too rapidly may damage the internal actuator gear or the power transmission system.

### CAUTION

**Never pull directly on the damper blade to open or close the device. This may result in damage of the self-locking driving gear of the damper, and is not covered by warranty.**

# mcr WIP PRO multi-blade fire damper

## Trigger control gears

The following trigger control gears are available for the mcr WIP PRO fire dampers:

### Electric actuator:

BF 230-T	/S	N	N-M	/T	/G	BE 230	/S	N	N-M	/T	/G
BF 24-T (-ST)	/S	N	N-M	/T	/G	BE 24 (-ST)	/S	N	N-M	/T	/G
BF 24-T-TL	/S	N	N-M	/T	/G	BLE 230	/S	N	N-M	/T	/G
BFL 230-T	/S	N	N-M	/T	/G	BLE 24 (-ST)	/S	N	N-M	/T	/G
BFL 24-T (-ST)	/S	N	N-M	/T	/G	EXBF 230	/S	N	N-M	/T	/G
BFN 230-T	/S	N	N-M	/T	/G	EXBF 24	/S	N	N-M	/T	/G
BFN 24-T (-ST)	/S	N	N-M	/T	/G	BF 230-TN	/S	N	N-M	/T	/G
BF 24-TN (-ST)	/S	N	N-M	/T	/G	BF 24-TN-TL	/S	N	N-M	/T	/G
BEE 230	/S	N	N-M	/T	/G	BEE 24 (-ST)	/S	N	N-M	/T	/G
BEN 230	/S	N	N-M	/T	/G	BEN 24 (-ST)	/S	N	N-M	/T	/G

### Spring gear:

RST	/S	N	M	/T	/G	RST/KW1/S	/S	N	M	/T	/G
RST/KW1/24P	/S	N	M	/T	/G	RST/KW1/24I	/S	N	M	/T	/G
RST/KW1/230P	/S	N	M	/T	/G	RST/KW1/230I	/S	N	M	/T	/G

## Basic dimensions

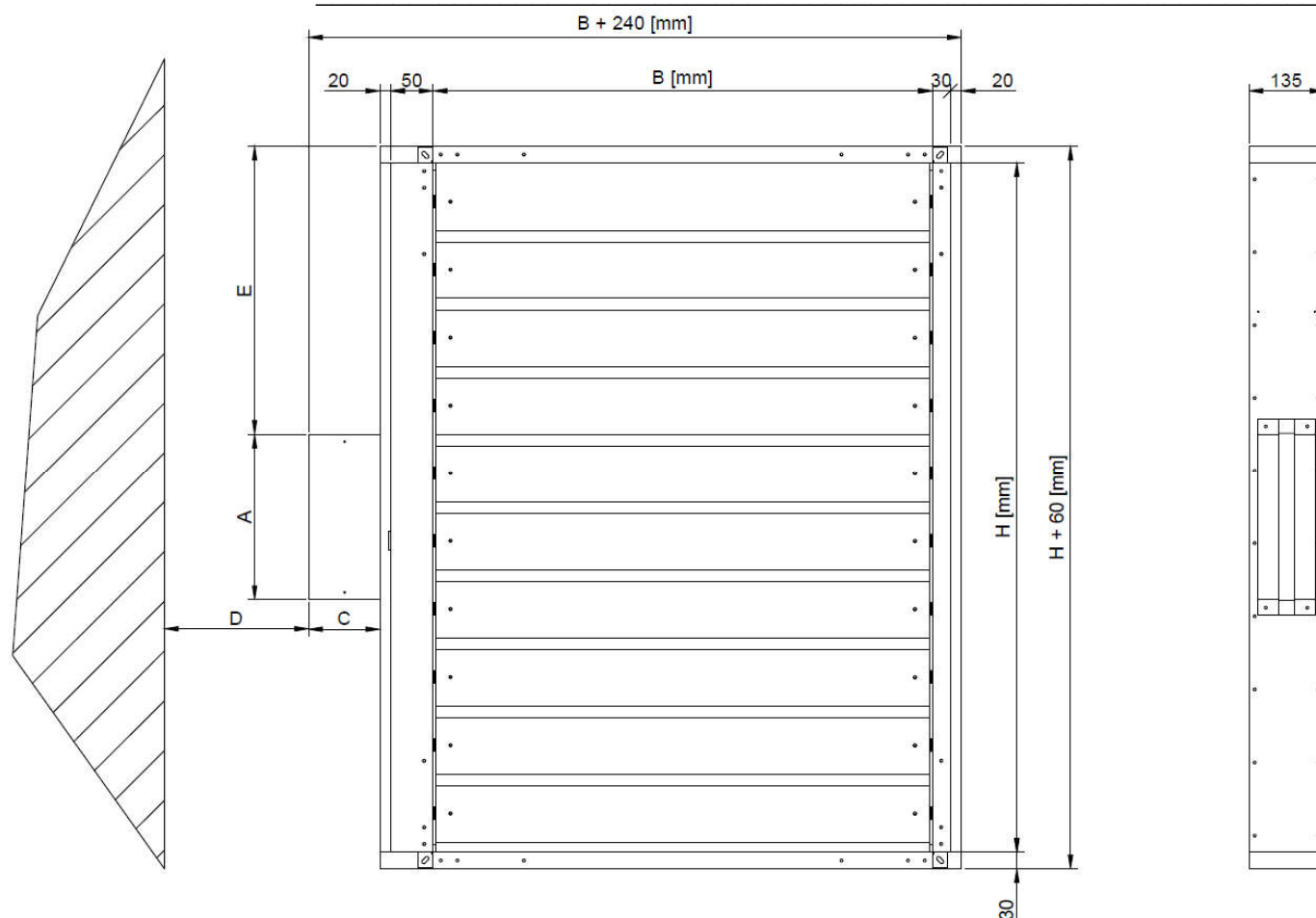

Fig. Fire damper mcr WIP PRO with electric actuator BELIMO.

Mechanizm	A	C	D	E
BF, BLF, BFL, BFN, BE, BLE	298	120	75	wzór

# mcr WIP PRO multi-blade fire damper

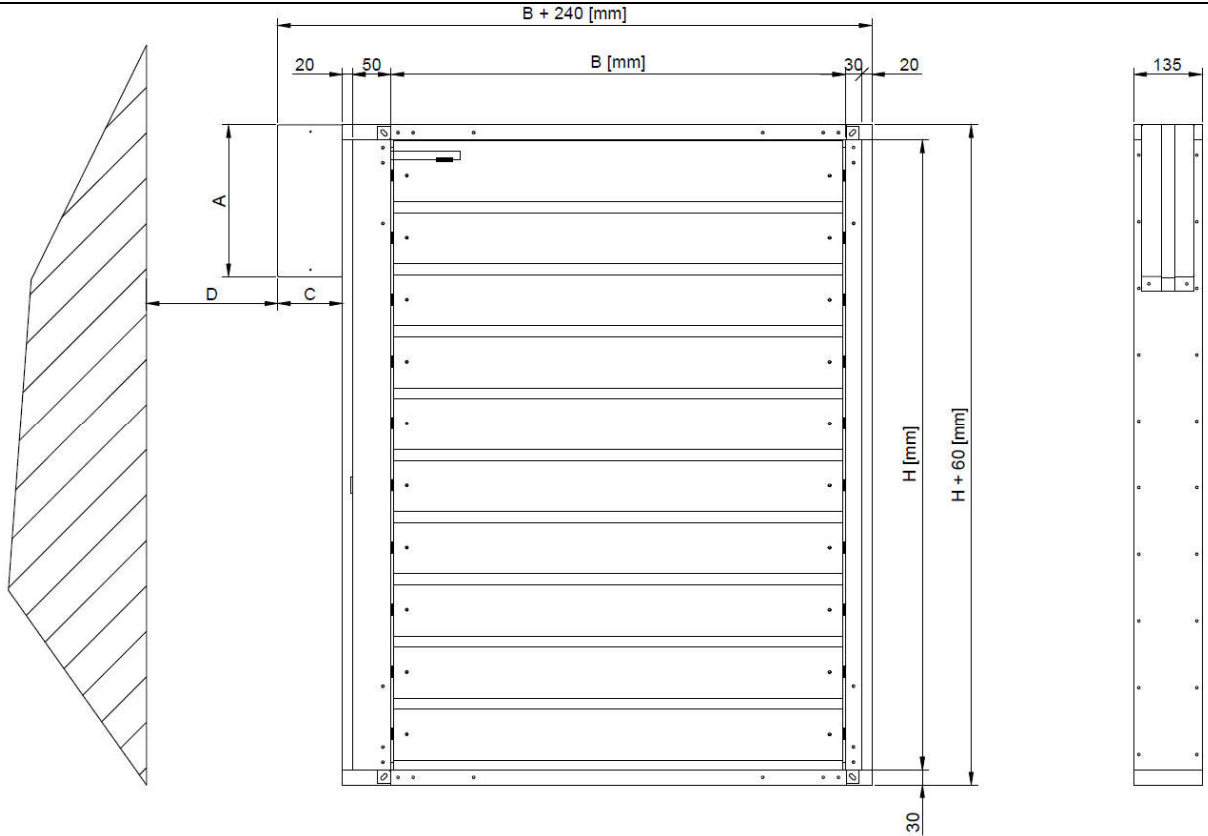
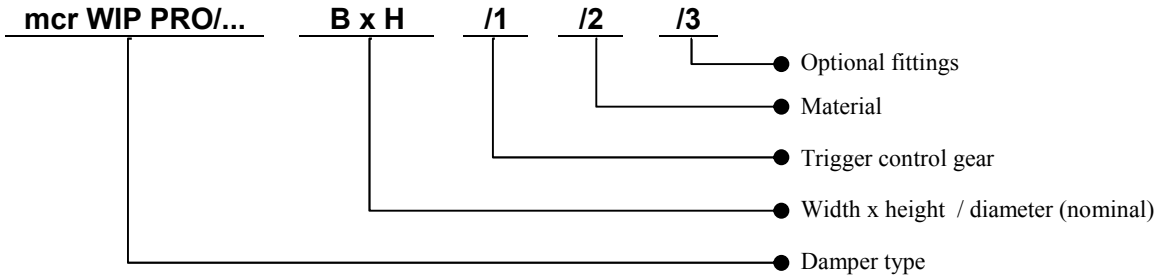

Fig. Fire dapmer mcr WIP PRO with spring gear.

Mechanizm	A	C	D
RST/KW1/S,RST/KW1/24P	298	120	75

## 5. DEVICE IDENTIFICATION



## 6. INSTALLATION

### CAUTION

During the installation of the damper and finishing works with it, there is a need to consider possibility of future access to the device and possibility of disassembly the control-release mechanism in order to perform maintenance or technical review.

The mcr WIP PRO dampers can be installed in the following building partitions (i.e. walls or ceilings):

- masonry concrete walls min. 120 [mm] thick in variants /S, /T, /V, /V-M
- masonry walls made of bricks or blocks min. 120 [mm] thick in variants /S, /T, /V, /V-M
- panel walls min. 125 [mm] thick in variants /S, /T, /V, /V-M
- floor slabs min. 150 [mm] thick in variant /S

\*Dampers mounted in the floor slabs, may have a maximum dimension BxH: 1000x1000mm

Additionally, the fire dampers can be installed:

- outside of walls
- in dampers sets (multiple damper sets)

# mcr WIP PRO multi-blade fire damper

The mcr WIP PRO shut-off fire dampers may also be installed in partitions with a lower class of fire resistance. In such case the damper fire resistance is equal to the partition fire resistance, if the smoke tightness factor is met. When installing the fire damper in a wall, the thickness of which is narrower than required minimum, increase the thickness at the installation location i.e.: by adding an extra board or other suitable construction material on the damper perimeter.

## 6.1. PRE-ASSEMBLY INSPECTION

Each fire damper is inspected by the manufacturer before packing and shipping. After unpacking the delivered damper, visually examine it for any damage or casing deformations, which could have occurred during transport.

## 6.2. INSTALLATION OPENING

The minimum dimensions of the installation opening, which allow correct installation of the mcr WIP PRO damper are:

$$B_o=(B+240)+40[\text{mm}] \quad H_o=(H+60)+40[\text{mm}]$$

Dimension “Z” (distance from the fire damper top edge and the trigger control gear guard box)  
 - depends on the dimension H and the applied trigger control gear type:

Gear type	Even number of blades	Odd number of blades
Belimo BF, BLF, BFL, BFN, BE, BLE	$Z [\text{mm}] = (H/2 - 123) + 30$	$Z [\text{mm}] = (H/2 - 61.5) + 30$
RST/KW1/S, RST/KW1/24P	$Z [\text{mm}] = 0$	$Z [\text{mm}] = 0$

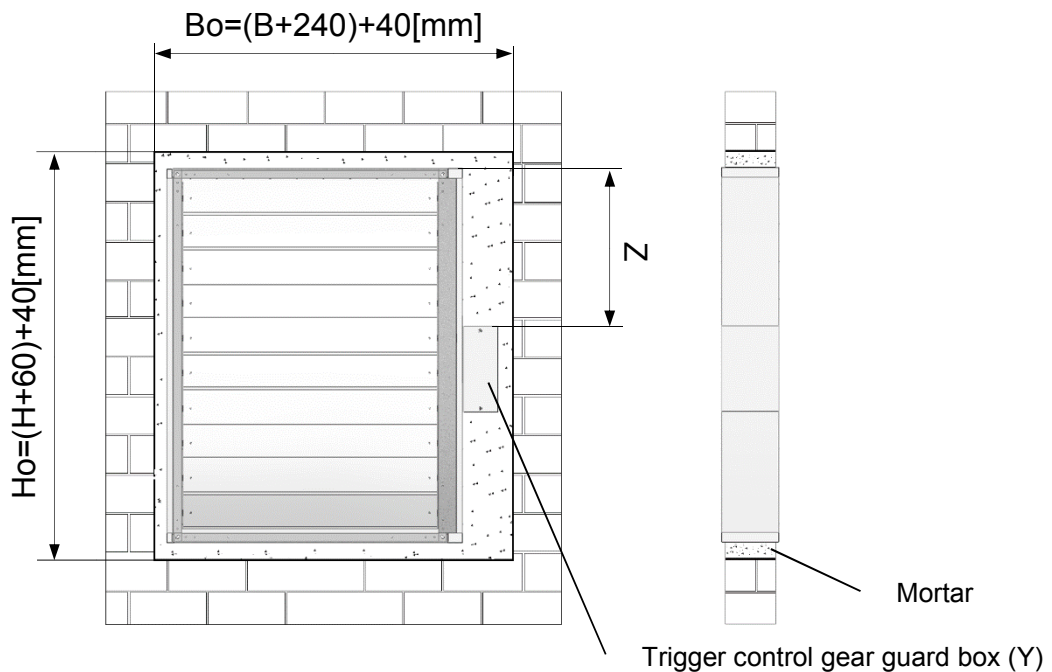

## 6.3. EMBEDDING / SETTING THE DAMPER

As standard, the mcr WIP PRO fire dampers should work in a position where the partition rotation axis is a horizontal axis. The need to install the damper with a vertical axis of rotation should be notified when ordering. The release and control mechanism can be located on the right or left side of the damper in any direction of air flow. Before bricklaying / embedding in a building partition, place the damper axially in the partition (wall or ceiling, constituting the separation of the fire zone) in the previously prepared opening. Then level and immobilize the device. After these operations, manually activate the damper partition, checking that it rotates correctly (does not interfere with the housing elements, etc.). Close the damper blade. The gap between the damper casing and the wall should be carefully filled with a suitable mortar, ensuring fire resistance of the wall and the damper, paying special attention that it does not get on the damper actuators (release mechanism, partition, seals, limiters). To this end, prior to assembly, the damper must be protected with foil or other covering material until masonry and finishing works are completed. The partition must remain closed until the mortar sets. After setting the mortar, open and close the damper again to check its correct operation. When installing the damper in a wall made of panels, the space between the damper casing and the wall should be tightly filled with mineral wool, having a non-flammable class A1 (confirmed by a certificate), and density and thickness ensuring fire resistance not less than the wall resistance in which the

## **mcr WIP PRO** multi-blade fire damper

---

damper is installed. The filled space should be additionally sealed with a suitable mortar or putty having fire resistance required for the wall.

It is possible to install the damper on a vertical or horizontal section of the fire ventilation duct across this duct or on the sides of the above mentioned duct. The damper can also be mounted in a building shaft used for fire ventilation. The acceptable assembly is illustrated by the drawings later in the document.

Before walling / mounting the damper in a fire ventilation duct or in a building shaft used for fire ventilation, place the damper axially in the previously prepared hole. Then the device should be leveled and immobilized. After these operations, manually activate the damper partition, checking that it rotates correctly (does not interfere with the housing elements, etc.). Close the damper blade. The gap between the damper casing and the duct / shaft should be carefully filled with an appropriate mortar / glue ensuring fire resistance of the duct / shaft and the damper, paying particular attention that it does not get on the damper actuators (release mechanism, partition, seals, limiters). To this end, prior to assembly, the damper must be protected with foil or other covering material until masonry and finishing works are completed. The partition must remain closed until the mortar / adhesive has set. After setting the mortar / adhesive, open and close the damper again to check its proper functioning.

During fire damper installation in a floor slab, make a frame from Z-bars and set the fire damper in it. Carefully fill the gap between the damper casing and the floor slab with a proper and certified mortar compound that ensures proper wall and damper fire resistance, and do not let the mortar get into the damper actuation components (i.e. the trigger control gear, the damper blade, gaskets and stops). To do this, the fire damper must be covered with plastic film or other suitable material and remain so until the embedding and finishing is done.

In order to ensure the fire resistance of the fire separation element, the damper blades rotation axis cannot be situated outside the wall face.

If the fire partition (wall) thickness is similar to the length of fire damper, it is recommended to install the fire damper in way, where axis of the damper is aligned with the building partition cross section centre. The embedded fire damper must be coaxially connected to the ventilation duct. Protect the fire damper casing from damage, and specifically from straining the casing during the installation process. The fire damper cannot bear the load of the ventilation duct or the ventilation system in which it is installed. Using drills, screws, bolts or other elements that pierce through the casing to the inside of the damper is prohibited. Once connected to the ventilation ducts, re-verify the fire damper performance. During the installation of the mcr WIP PRO fire damper, keep in mind, that the thermal trigger (a fusible link) must not be damaged or exposed to high temperature (from fire, and welding/soldering equipment), which might release it (it is a single use element and is not subjected to warranty replacement). Do not expose the intumescent gaskets installed in the fire damper casing to high temperature. It is impossible to close the damper, when gaskets are swollen. After installation, carefully clean the fire damper and make sure that there is no debris which could obstruct proper performance of the device.



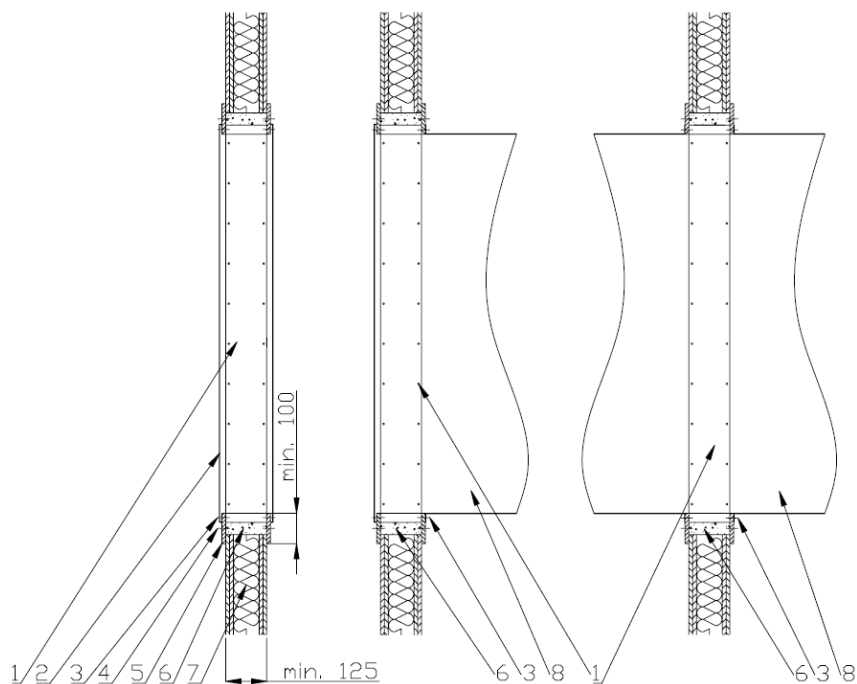

- 1 – mcr WIP PRO damper
- 2 – Cover grille
- 3 – M10 fixing screw

- 4 – M8 dowel
- 5 – Frame from plasterboard
- 6 – Eg gypsum mortar

- 7 – Flexible wall
- 8 – Ventilation duct

**Fig. Mounting the mcr WIP PRO fire damper in a GK wall**

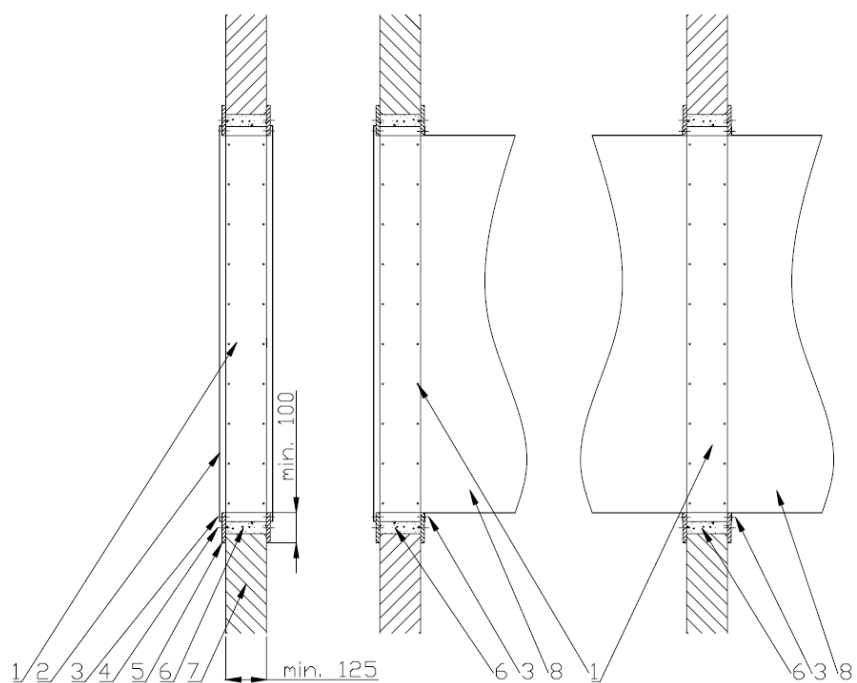

- 1 – mcr WIP PRO damper
- 2 – Cover grille
- 3 – M10 fixing screw

- 4 – M8 dowel
- 5 – Frame from plasterboard
- 6 – Eg gypsum mortar

- 7 – Flexible wall
- 8 – Ventilation duct

**Fig. Mounting the mcr WIP PRO fire damper in a solid wall**

# mcr WIP PRO multi-blade fire damper

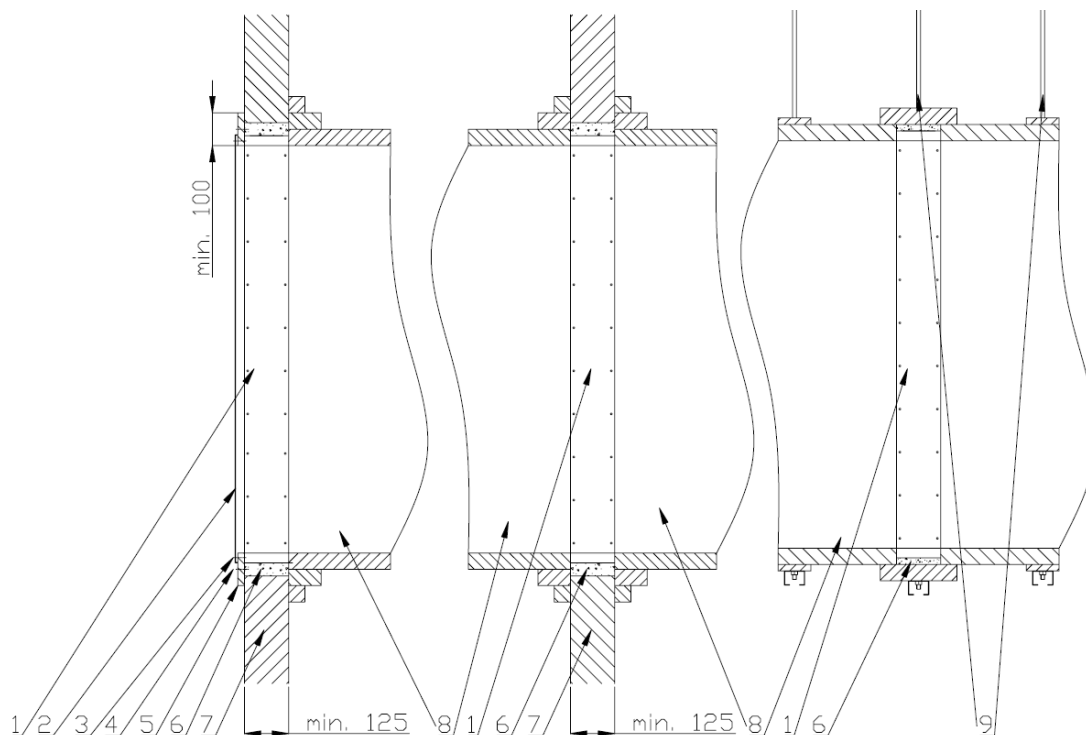

- 1 – mcr WIP PRO damper
- 2 – Cover grille
- 3 – M10 fixing screw

- 4 – M8 dowel
- 5 – Frame from fireproof board 20mm thick
- 6 – Eg gypsum mortar

- 7 – Building partition
- 8 – Smoke extraction duct\*
- 9 -Suspension system

**Fig. Installation of the mcr WIP PRO damper in fire ventilation systems**

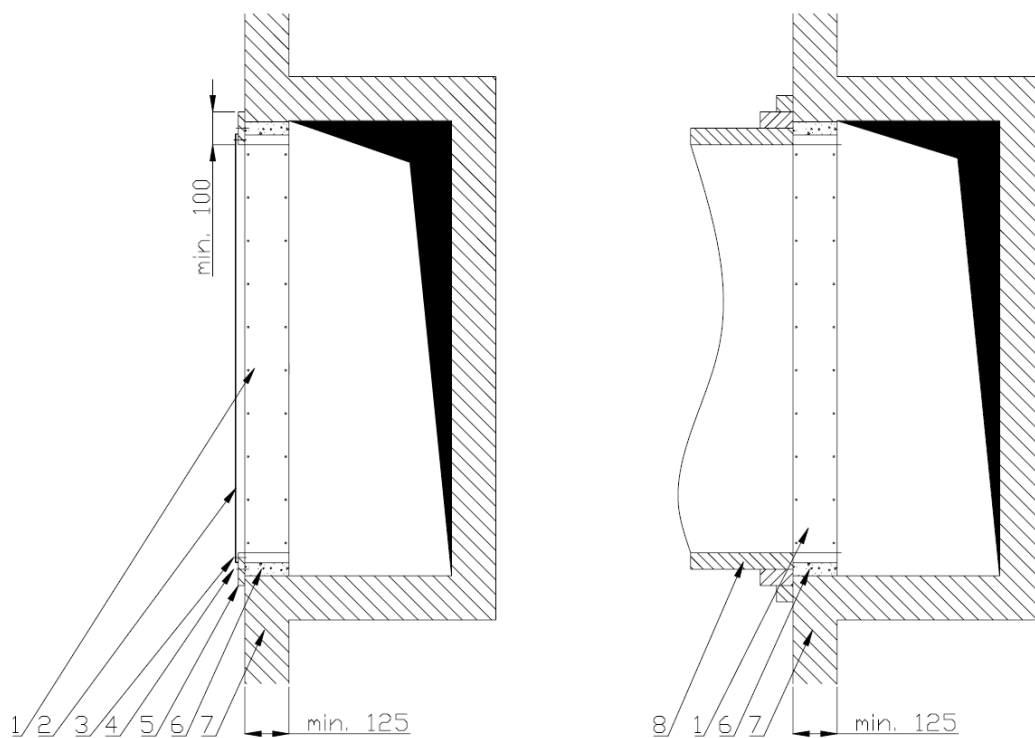

- 1 – mcr WIP PRO damper
- 2 – Cover grille
- 3 – M10 fixing screw

- 4 – M8 dowel
- 5 – Frame from fireproof board 20mm thick
- 6 – Eg gypsum mortar

- 7 – Building partition
- 8 – Smoke extraction duct\*

**Fig. Installation of the mcr WIP PRO damper in fire ventilation systems.**

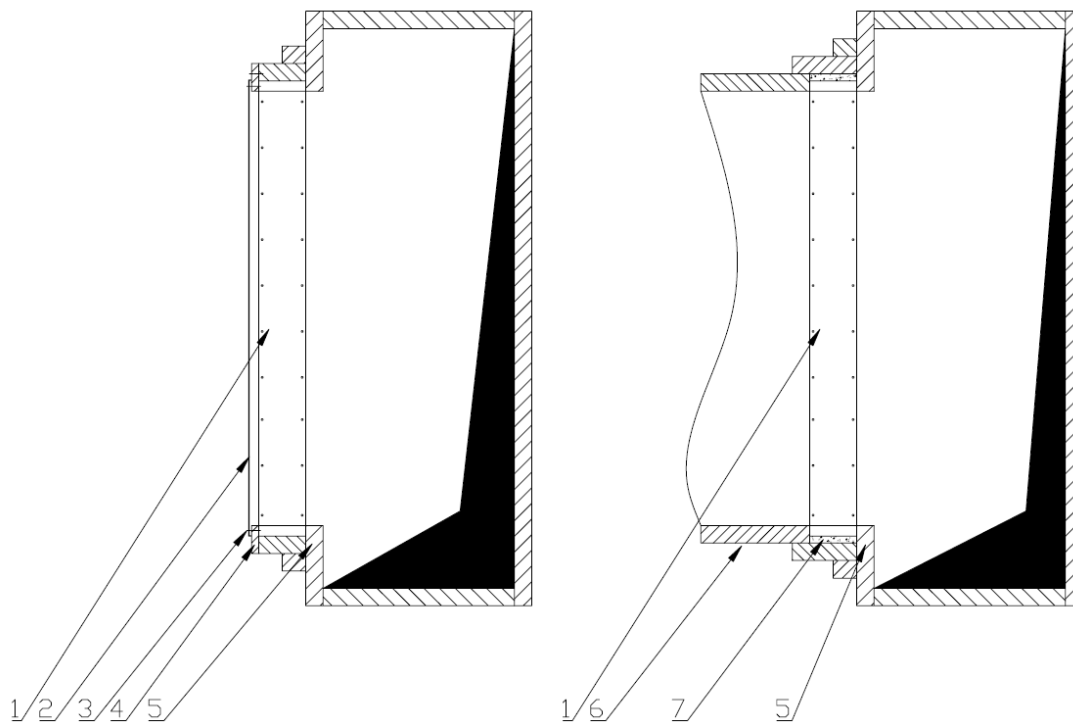

1 – mcr WIP PRO damper  
 2 – Cover grille  
 3 – M10 fixing screw

4 – Frame from fireproof board 20mm thick  
 5 – Vertical smoke extraction duct\*  
 6 – Horizontal smoke extraction duct\*

7 – Eg gypsum mortar

**Fig. Installation of the mcr WIP PRO damper in fire ventilation systems**

## CAUTION

\* Smoke extraction duct should be made in accordance with the duct manufacturer's guidelines. The ducts must have adequate fire resistance in accordance with the fire resistance provided for the entire solution. Seal all connections between the damper and the ducts with appropriate mortar / glue / gaskets, ensuring fire resistance. The shut-off damper in vertical position fire ventilation systems may be mounted across the horizontal smoke extract duct or on the sides of the horizontal smoke extract duct or on the surface of any side of the vertical smoke extract duct.

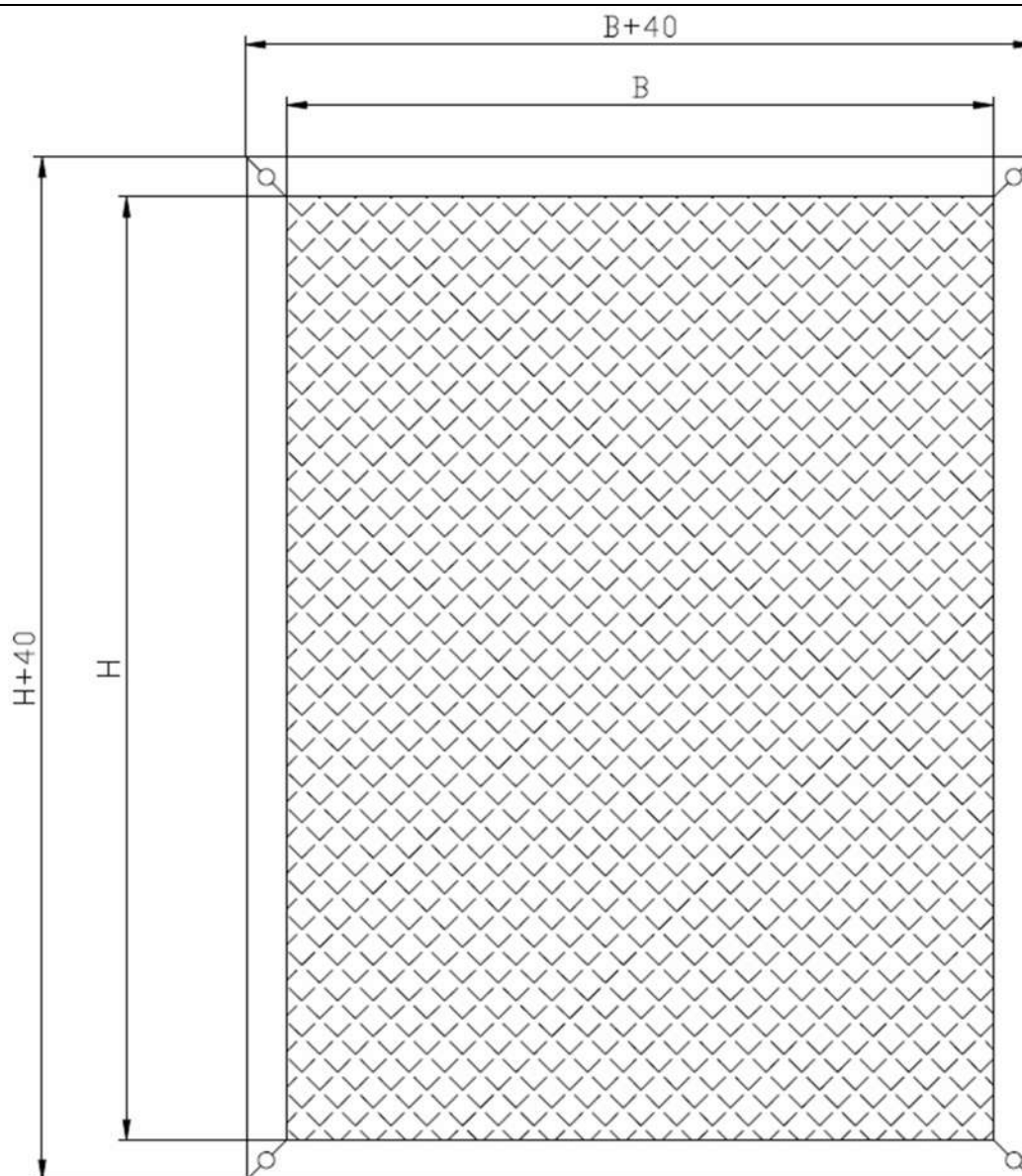

**Fig.. Modular masking grill mcr WIP PRO**

The masking grid can be supplied as a modular by the damper manufacturer. The solution of system masking grates dedicated in particular to usable spaces with high architectural and functional requirements, allows covering additional damper with any other masking grid while meeting the requirements of mcr WIP PRO fire damper classification.

# mcr WIP PRO multi-blade fire damper

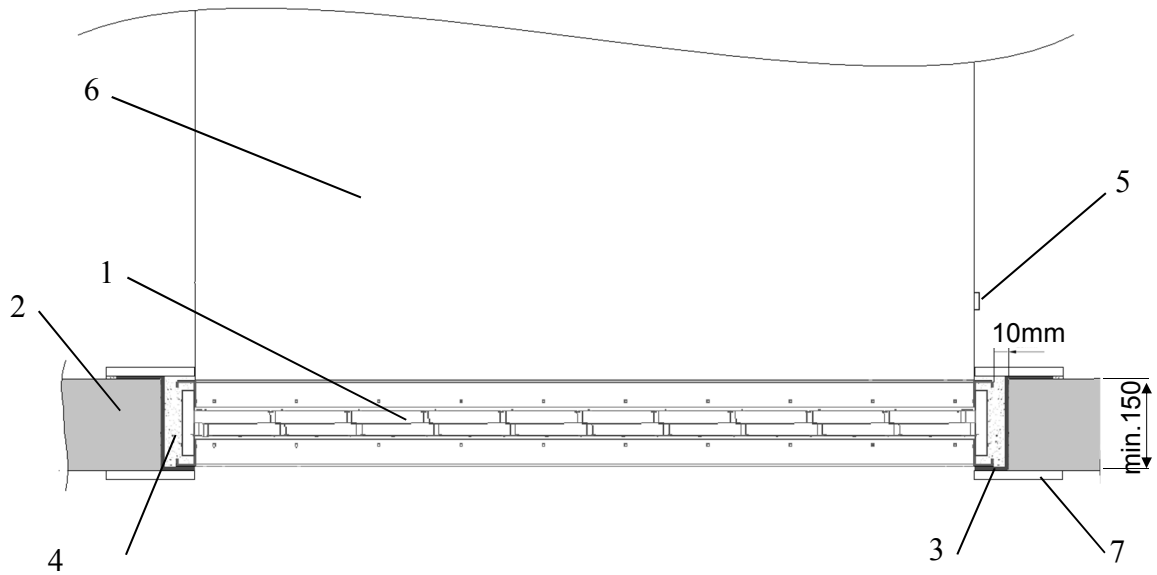

1 - Fire damper  
 2 - Concrete floor slab, min. thickness: 150 mm  
 3 - Mounting Z-bars

4 - Cement mortar  
 5 - Thermal trigger (installed in the duct 100 mm from the fire damper)

6 - Steel duct  
 7 - Plasterboard rims, 100 mm x 12.5 mm

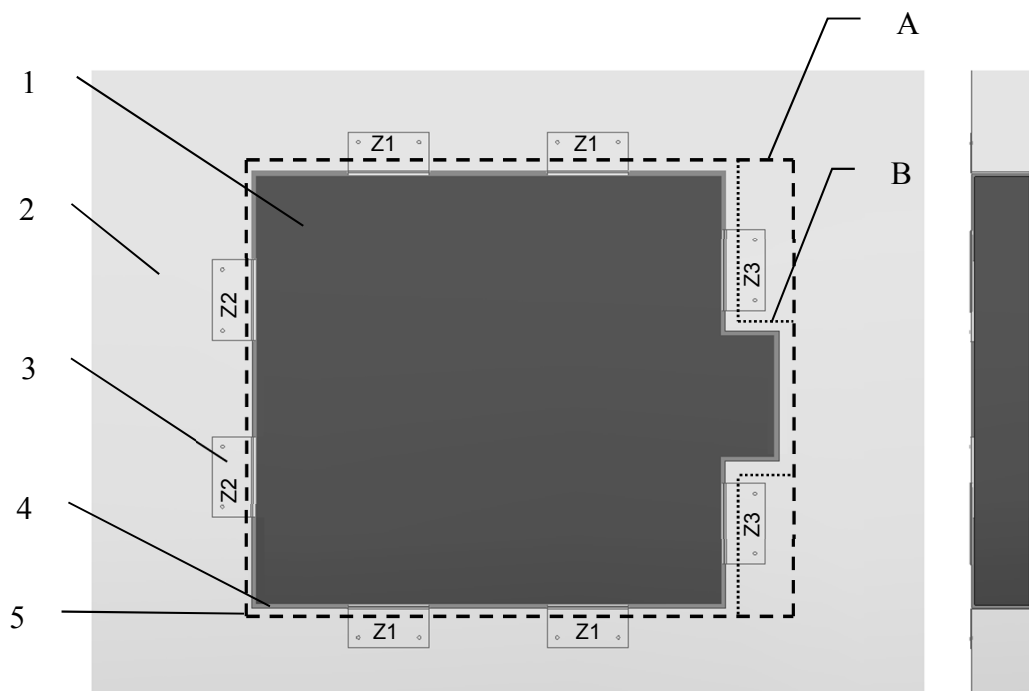

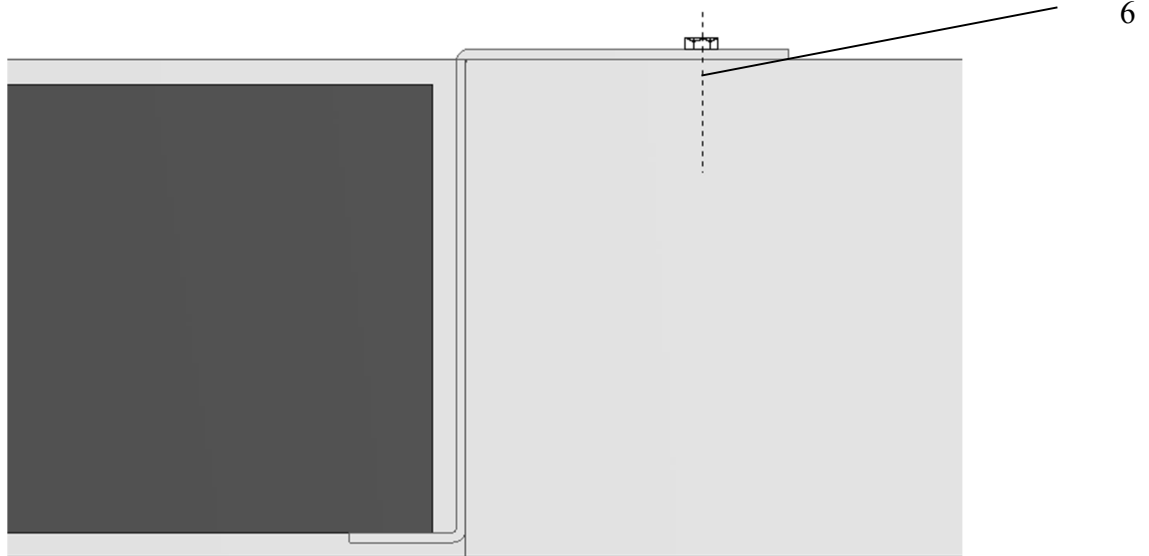

- 1 - Fire damper
- 2 - Concrete floor slab, min. thickness: 150 mm
- 3 - Mounting Z-bars
- 4 - Cement mortar
- 5 - Installation opening
- 6 - Installation plug, M8x80 mm

**Fig. Example installation of the mcr WIP PRO fire damper in a floor slab, min. thickness 150 mm, min. fire resistance rating: EI120 Installation gap: 10 mm.**

The Z-bars are installed from below of the fire damper, Z-bars are selected accordingly to the fire damper frame width.

### CAUTION:

**The Z-bars are not delivered in package with fire damper set.**

If the installation opening is prepared with a place for control-release mechanism (B), use Z3 Z-bars with dimensions as shown in the figure below.

If the installation opening (A) is prepares in rectangle shape, extend the Z3 Z-bars by 120 mm in relation to the dimensions given in the figure below.

Required number of Z elements for particular lengths of the damper sides:

- Z1: 1 piece for side  $B \leq 500\text{mm}$   
2 pieces for side  $B > 500\text{mm}$
- Z2: 1 piece for side  $H \leq 500\text{mm}$   
2 pieces for side  $H > 500\text{mm}$
- Z3: 1 piece for the side  $H \leq 700\text{mm}$   
2 pieces for side  $H > 700\text{mm}$

# mcr WIP PRO multi-blade fire damper

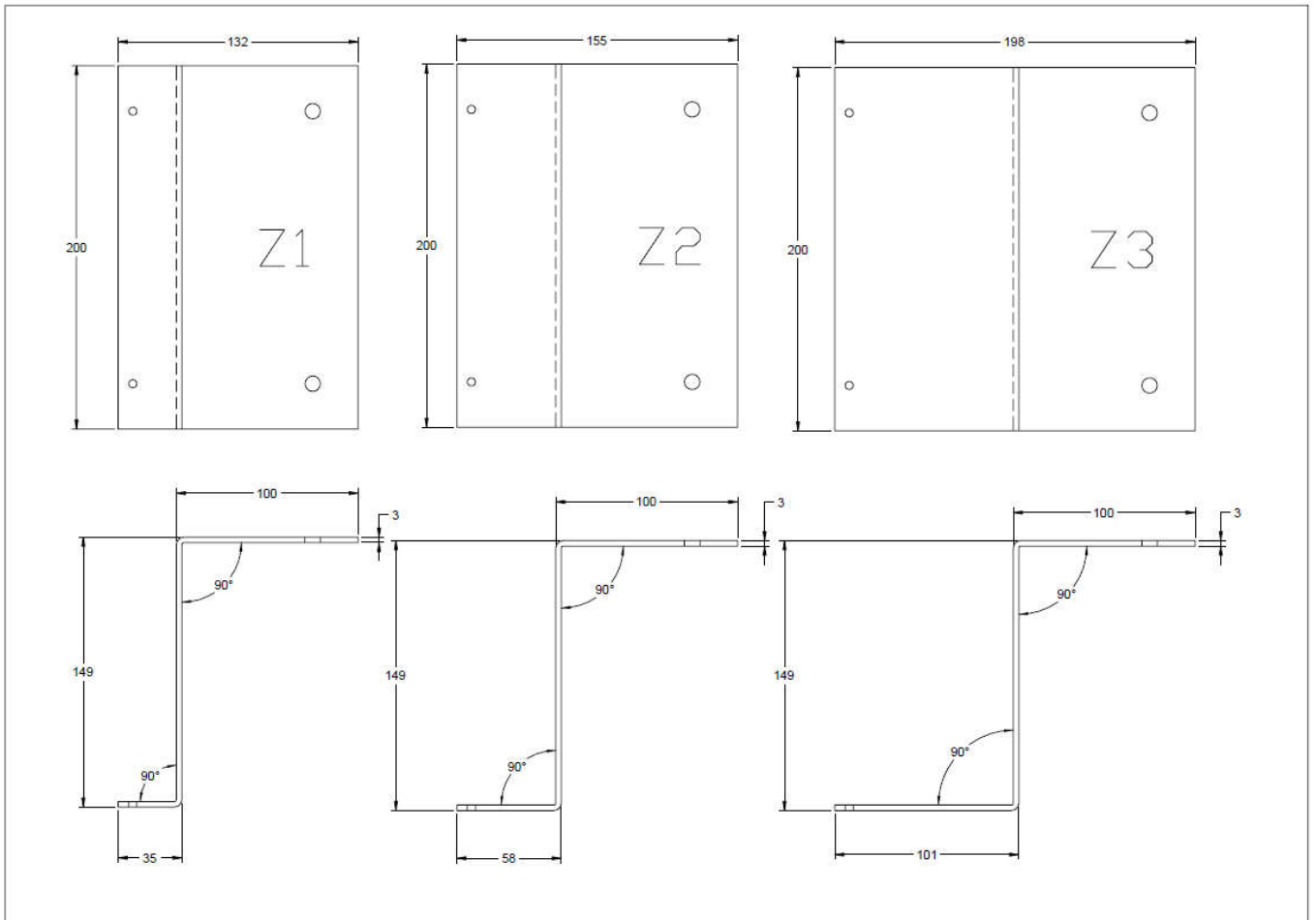

**Fig. Mounting Z-bars, installation of the mcr WIP PRO fire damper in a concrete ceiling slab with min. thickness: 150 mm, min. fire resistance rating: R120**

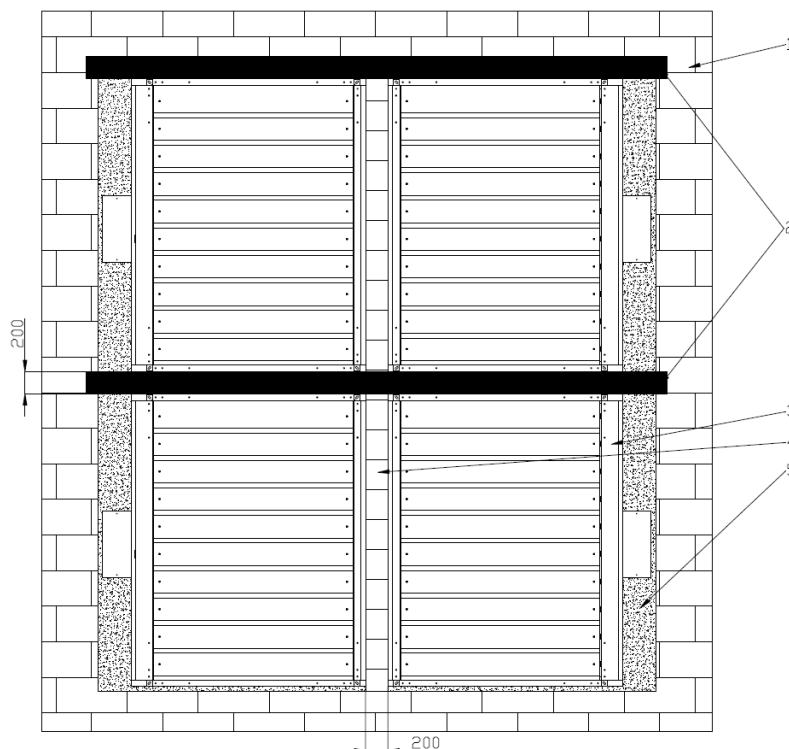

1 – e.g. a masonry wall

2 – A building element with fire resistance equal or higher to the building envelope resistance

3 – mcr WIP PRO/ ... fire damper, BxH.

4 – A building element with fire resistance equal or higher to the building envelope resistance. For example, a brick wall.

5 – e.g. mortar

**Fig. Installation of the mcr WIP PRO/ ... fire damper as a multiple damper set (a set of 4)**

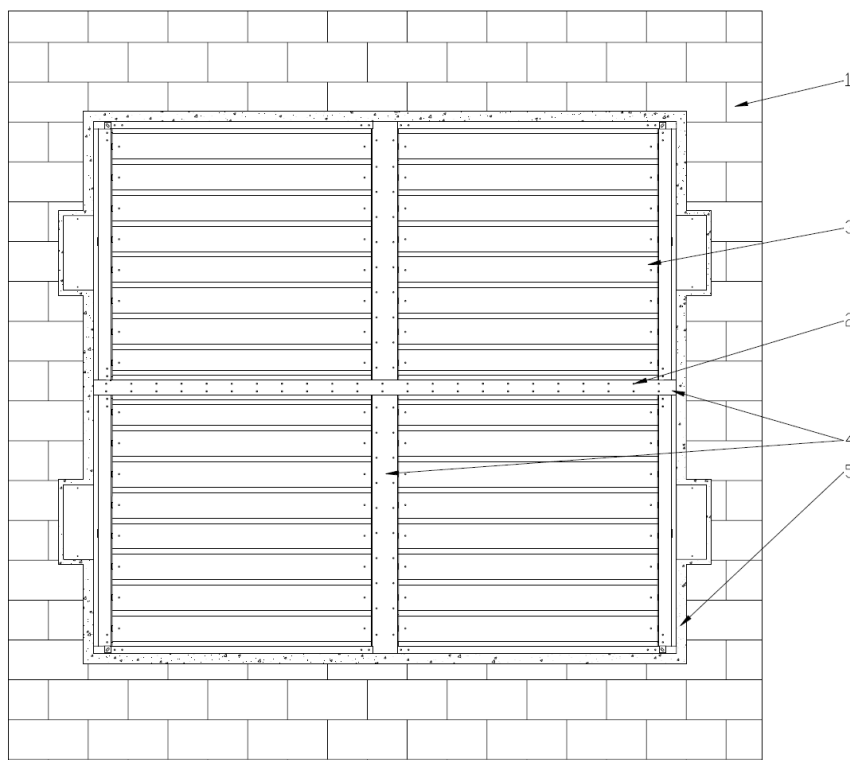

1 – e.g. a masonry wall

2 – M5x20 sheet metal screw

3 – mcr WIP PRO damper module

4 – C-profile - thickness 2mm

5 – e.g. mortar

During installation, keep a 10mm gap between the fire dampers, filled with A1 class wool. Joints should be sealed with high-temperature silicone.

**Rys. Installation of the mcr WIP PRO/ ... fire damper as a multiple damper set (a set of 4)**



## mcr WIP PRO multi-blade fire damper

Other configurations of the mcr WIP PRO/ ... dampers modules can be made, consisting of two or more dampers, while maintaining the minimum distances between the dampers according to the drawing above.

For the installation of ventilation ducts are provided the rivet nuts in the corners of the damper. In case of need for additional anchorage of the ventilation duct to the damper, it is possible to use hexagon—type self-tapping screws K type ST 3,5x13mm made of galvanized steel according to DIN 7504. The assembly is possible to the steel frame of the damper in distances shown below:

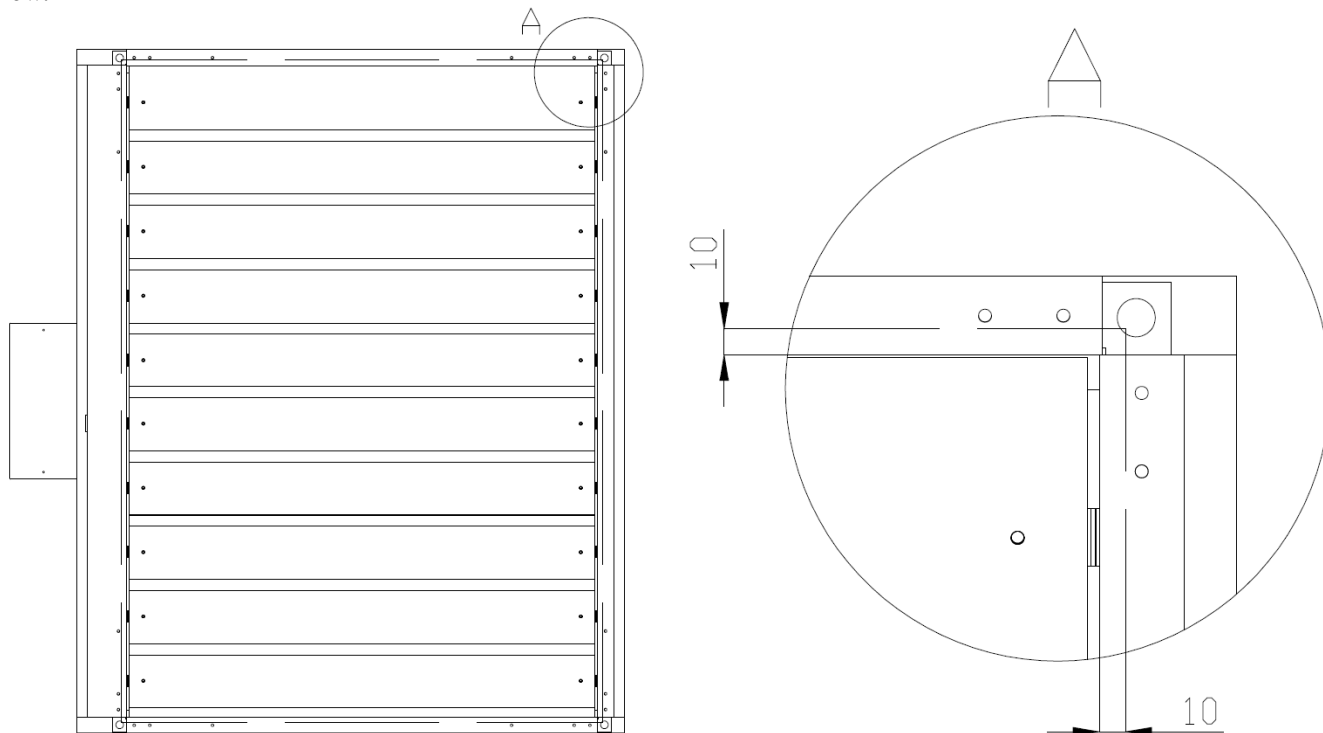

**Fig. Installation of ventilation ducts.**

# mcr WIP PRO multi-blade fire damper

## 6.4. ELECTRICAL CONNECTIONS

If the damper has control elements or other parts which need to be connected to the electrical grid, they should be connected after correct mounting of fire damper in the wall. Below are showed connection diagrams and basic electrical data of control-release mechanisms with which fire dampers mcr WIP PRO are supplied.

The thermal trigger is supplied with its baseplate for DIY installation. Fasten the thermal trigger with two sheet screws to the device flange or the duct in a location clear of the fire damper blade rotation radius.

### Electric actuators – electrical specification

Actuator type	Location of the damper isolation partition
- Belimo BFL series - Belimo BFN series - Belimo BF series	Open isolation partition – actuator indication: 90 Closed isolation partition – actuator indication: 0
- Belimo serii BE - Belimo serii BLE - Belimo serii BEE - Belimo serii BEN	Open isolation partition – actuator indication: 0 Closed isolation partition – actuator indication: 90

Technical specifications	BF 24, BF24-T, BF24-TN	BF230, BF230-T, BF230-TN
Power supply	AC 24V 50/60Hz DC 24V	AC 220-240V 50/60 Hz
Power demand:		
- for spring tensioning	7 W	8,5 W
- for spring holding	2 W	3 W
Sizing (apparent power)	10 VA	11 VA
Appliance class	III	II
Ingress protection rating	IP 54	IP 54
Auxiliary circuit breaker:	2xSPDT 6 (3) A, 250V	2xSPDT 3 A, 250V~
- activation position [degrees]	5°, 80°	5°, 80°
Torque:		
- motor	18 Nm	18 Nm
- spring	12 Nm	12 Nm
Cable connection:		
- motor (L = 0.9 m)	2x0,75 mm <sup>2</sup>	2x0,75 mm <sup>2</sup>
- auxiliary circuit breaker	6x0,75 mm <sup>2</sup>	6x0,75 mm <sup>2</sup>
Movement time: (0-90°)		
- motor	120 s	120 s
- return spring	16 s	16 s
Operating temperature range	- 30 ...+50°C	- 30 ...+50°C
Sound pressure level:		
- motor	max 45 dB (A)	max 45 dB (A)
- spring	~ 63 dB (A)	~ 63 dB (A)

Technical specifications - Actuators	BE24, BE24-ST	BE230	BLE24, BLE24-ST	BLE230
Power supply	AC 24V 50/60Hz DC 24 V	AC 220-240V 50/60 Hz	AC 24V 50/60Hz DC 24V	AC 220-240V 50/60 Hz
Power demand:				
- for spring tensioning	12 W	8 W	7.5 W	5 W
- for spring holding	0,5W	0,5 W	0,5 W	1 W
Sizing (apparent power)	18 VA	15 VA	9 VA	12 VA
Appliance class	III	II	III	II
Ingress protection rating	IP 54	IP 54	IP 54	IP 54
Auxiliary circuit breaker:	2xSPDT 6(3) A, 250V	2xSPDT 6(3) A, 250V	2xSPDT 3A, AC 250V	2xSPDT 3A, AC 250V
- activation position [degrees]	3°, 87°	3°, 87°	3°, 87°	3°, 87°
Torque:				
- motor	40 Nm	40 Nm	15 Nm	15 Nm
- locking	50 Nm	50 Nm	20 Nm	20 Nm
Cable connection:				
- motor (L = 0.9 m)	3x0,75 mm <sup>2</sup>	3x0,75 mm <sup>2</sup>	3x0,75 mm <sup>2</sup>	3x0,75 mm <sup>2</sup>
- auxiliary circuit breaker	6x0,75 mm <sup>2</sup>	6x0,75 mm <sup>2</sup>	6x0,75 mm <sup>2</sup>	6x0,75 mm <sup>2</sup>
Movement time: (0-90°)				
- motor	60s	60 s	30 s	30 s
Operating temperature range	- 30 ...+50°C	- 30 ...+50°C	- 30 ...+50°C	- 30 ...+50°C
Sound pressure level:				
- motor	max 62 dB (A)	max 62 dB (A)	max 62 dB (A)	max 62 dB (A)

# mcr WIP PRO multi-blade fire damper

Technical specifications - Actuators	BEE24, BEE24-ST	BEE230	BEN24, BEN24-ST	BEN230
Power supply	AC 24V 50/60Hz DC 24 V	AC 220-240V 50/60 Hz	AC 24V 50/60Hz DC 24V	AC 220-240V 50/60 Hz
Power demand: - for spring tensioning - for spring holding	2,5 W 0,1W	3,5 W 0,4 W	3 W 0,1 W	4 W 0,4 W
Sizing (apparent power)	5 VA	6 VA	6 VA	7 VA
Appliance class	III	II	III	II
Ingress protection rating	IP 54	IP 54	IP 54	IP 54
Auxiliary circuit breaker: - activation position [degrees]	2xSPDT 3A AC 250V 5°, 80°	2xSPDT 3A AC 250V 5°, 80°	2xSPDT 3A, AC 250V 5°, 80°	2xSPDT 3A, AC 250V 5°, 80°
Torque: - motor	25 Nm	25 Nm	15 Nm	15 Nm
Cable connection:				
- motor (L = 0.9 m)	3x0,75 mm <sup>2</sup>	3x0,75 mm <sup>2</sup>	3x0,75 mm <sup>2</sup>	3x0,75 mm <sup>2</sup>
- auxiliary circuit breaker	6x0,75 mm <sup>2</sup>	6x0,75 mm <sup>2</sup>	6x0,75 mm <sup>2</sup>	6x0,75 mm <sup>2</sup>
Movement time: (0-90°) - motor	60s	60 s	30 s	30 s
Operating temperature range	- 30 ...+55°C	- 30 ...+55°C	- 30 ...+55°C	- 30 ...+55°C
Sound pressure level: - motor	max 58 dB (A)	max 58 dB (A)	max 58 dB (A)	max 58 dB (A)

Technical data – actuators	BFL24, BFL24-T	BFL230, BFL230-T	BFN24, BFN24-T	BFN230, BFN230-T
Power supply	AC 24 V 50/60 Hz DC 24 V	AC 220–240 V 50/60 Hz	AC 24 V 50/60 Hz DC 24 V	AC 220-240V 50/60 Hz
Power demand: – when putting the spring under tension – when in standby	2.5 W 0.7 W	3,5 W 1.1 W	4 W 1.4 W	5 W 2.1 W
Apparent power	4 VA	6.5 VA	6 VA	10 VA
Protection class	III	II	III	II
IP rating	IP 54	IP 54	IP 54	IP 54
auxiliary switch: – activation point [degrees]	2 x PDT 3(0.5) A AC 250V 5°, 80°	2 x PDT 3(0.5) A AC 250V 5°, 80°	2 x SPDT 3(0.5) A, 250 V 5°, 80°	2 x SPDT 3(0.5) A, 250 V 5°, 80°
Torque: - motor - spring	4 Nm 3 Nm	4 Nm 3 Nm	9 Nm 7 Nm	9 Nm 7 Nm
Wire connection: – motor (length: 0.9 m) – auxiliary switch	2 x 0.75 mm <sup>2</sup> 6 x 0.75 mm <sup>2</sup>	2 x 0.75 mm <sup>2</sup> 6 x 0.75 mm <sup>2</sup>	2 x 0.75 mm <sup>2</sup> 6 x 0.75 mm <sup>2</sup>	2 x 0.75 mm <sup>2</sup> 6 x 0.75 mm <sup>2</sup>
Movement time (0–90°): - motor - return spring	60 s ≈ 20 s	60 ≈ 20 s	60 s ≈ 20 s	60 s ≈ 20 s
Working temperature range	-30 ...+55°C	-30 ...+55°C	-30 ...+55°C	-30 ...+55°C
Sound pressure level: - motor - spring	max 43 dB (A) ~ 62 dB (A)	max 43 dB (A) ~ 62 dB (A)	max 55 dB (A) ~ 67 dB (A)	max 55 dB (A) ~ 67 dB (A)

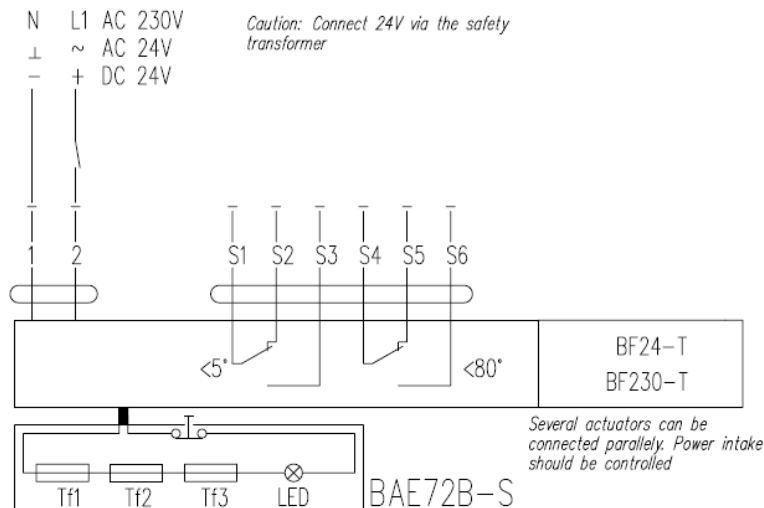

## Connection diagram for the BF24-Tand BF230-T actuators

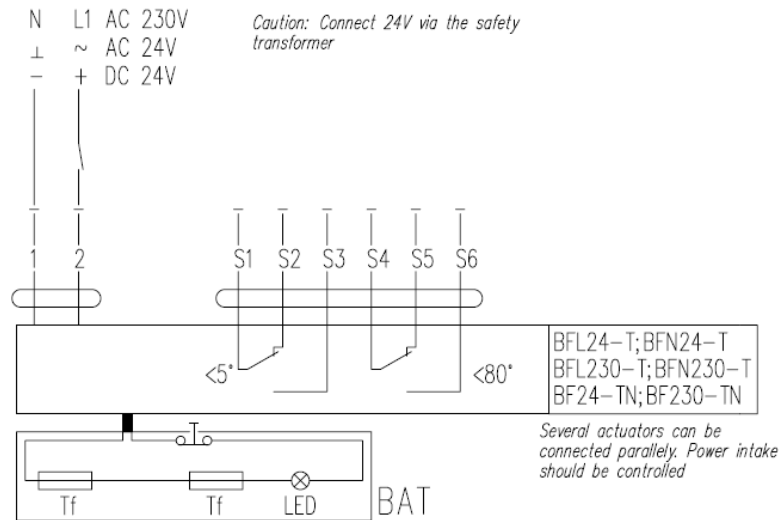

## Connection diagram for the BFL24-T, BFL230-T, BFN24-T, BFN230-T, BF24-TN and BF230-TN actuators

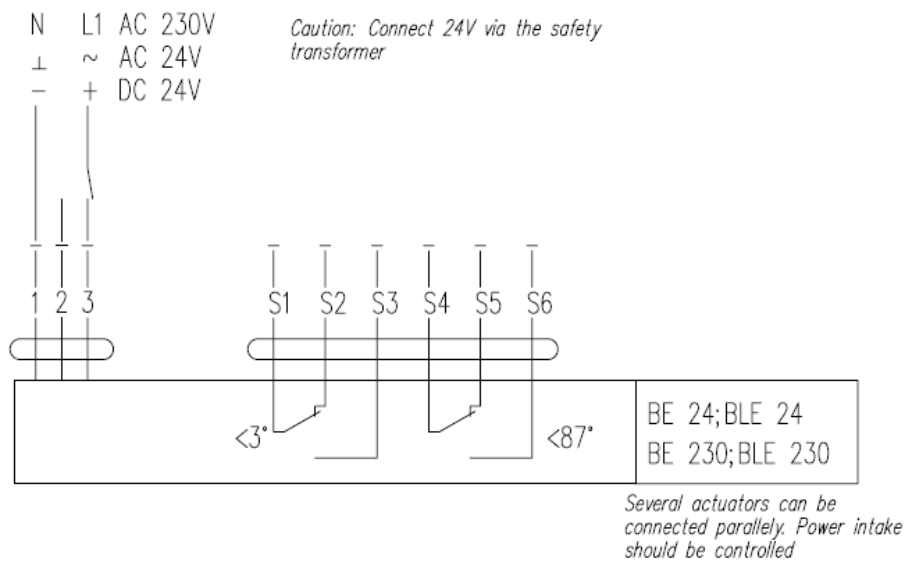

## Connection diagram for the BE24, BLE24, BE230 and BLE230 actuators

# mcr WIP PRO multi-blade fire damper

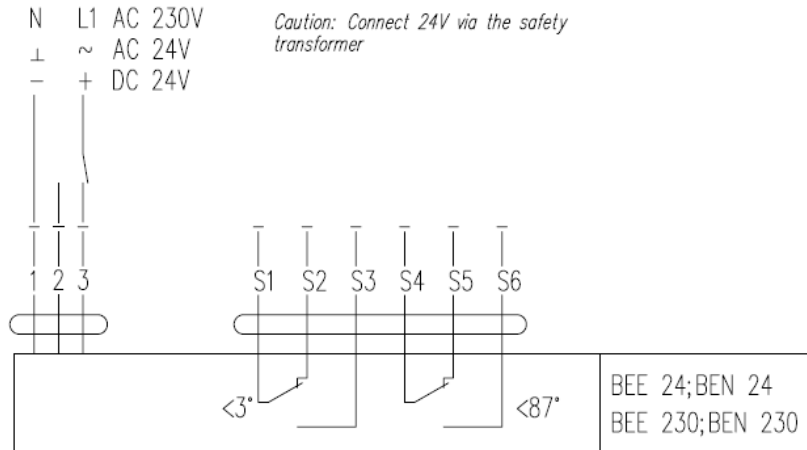

Several actuators can be connected parallelly. Power intake should be controlled

**Connection diagram for the BEE24, BEN24, BEE230 and BEN230 actuators**

**Note:**

The BE and BLE actuator operating control requires a three-wire system. The actuator sense of rotation is switched by applying the supply voltage to terminal 2 or 3, depending on the desired sense. The location of the limit switches for all types of actuators is shown for the position without voltage. For proper operation of a device equipped with electrical actuators, it is recommended that the rated voltage housed tolerance of 24V±10% or 230V±10%. Power supply devices other than listed above may cause malfunction and will not be covered by the warranty conditions.

**EXBF actuators**

Technical specifications	EXBF 24	EXBF 230
Zone		1, 2, 21, 22
ATEX classification	II 2 GD EEx d IIC T6	
Power supply	24 V AC ±20% 50/60 Hz / 24 VDC-10/+20%	230 V AC ±14% 50/60 Hz
Power demand:		
- for spring tensioning	7 W	8 W
- for spring holding	2 W	3 W
Sizing (apparent power)	10 VA	12.5 VA
Ingress protection rating	IP 66	IP 66
Auxiliary circuit breaker:	2 x SPDT 6A (3) max 250 V AC	2 x SPDT 6A (3) max 250 V AC
- activation position	5°, 80°	5°, 80°
Torque:		
- motor	18 Nm	18 Nm
- spring	12 Nm	12 Nm
Movement time: (90°)		
- motor	150 s	150 s
- return spring	≈20s	≈20s
Ambient temperature	- 20 ...+50°C	- 20 ...+50°C

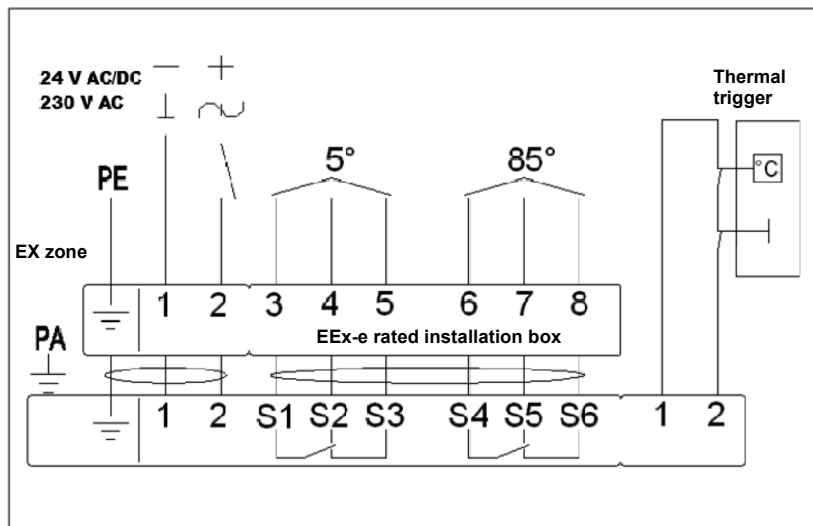

**Connection diagram for the EXBF actuators**

# mcr WIP PRO multi-blade fire damper

## Caution:

For proper operation of a device equipped with electrical actuators, it is recommended that the rated voltage housed tolerance of  $24V \pm 10\%$  or  $230V \pm 10\%$ . Power supply devices other than listed above may cause malfunction and will not be covered by the warranty conditions.

## RST/KW1 trigger control gear

The RST/KW1/S version has the limit switches installed in the gear itself. The electrical connections shall be made by connecting the properly labelled conductors to the electrical system. A fusible trigger is installed in the gear. The dampers with the RST/KW1/230I, RST/KW1/230P mechanisms, are supplied with the RST/KW1/24... triggering and control mechanism, together with the 230/24V transformer module type MP230/24. For the trigger and control mechanism of the "impulse" type damper, adequate power must be provided to ensure that the control signal is supplied to the device in the event of fire.

	RST/KW1/S	RST/KW1/24I	RST/KW1/24P	RST/KW1/24I +MP230/24	RST/KW1/24I +MP230/24
Supply voltage	X	24 V – 48 V DC	24 V – 48 V DC	230V AC	230V AC
Power consumption	X	3.5 W	1.6 W	4.5 W	2.5 W
Holding force	X	12 daN	12 daN	12 daN	12 daN
Thermal trigger trip point	72°C $\pm$ 2°C				
WK1d / WK2d limit switch	NO/NC (switching contact) 5A, 230V AC				
Switch trigger	3°, 87° – tolerance: $\pm$ 2°				
Limit switch operating temperature	-25 ...+85°C				
Electrical connection	X	- release: cable 0.6 m, 2x0.5 mm <sup>2</sup> - limit switch: cable 0.6 m, 6x0.5 mm <sup>2</sup>			

Rotation angle	92°				
Movement time	Max. 2s - spring				
Sense of rotation	CCW				
Gear weight	1.2 kg	1.4 kg	1.4 kg	1.5 kg	1.5 kg

KW1 gear power supply:	WK1 limit switch	WK2 limit switch
Wire number: 1-2	Wire number: 3-4 – NO (normally open)	Wire number: 6-7 – NO (normally open)
	Wire number: 4-5 – NC (normally closed)	Wire number: 7-8 – NC (normally closed)

### -MP 230/24

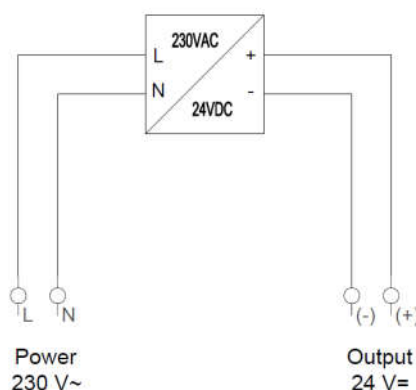

Connection diagram for transformer module type MP230/24.

**Caution! - The location of the limit switches is showed for the fire damper in the safety position.**

The RST/KW1 trigger control can work with the MP230/24 module. If the MP230/24 module is installed, the fire damper can be powered/controlled with voltage 230 V AC.

The proper performance of the device with electric actuators requires the rated supply voltage of  $24 V \pm 2\%$  or  $230 V \pm 2\%$ , as applicable. Other voltage values may cause operating malfunctions, that are not covered by the product warranty.

## 7. TRANSPORT & STORAGE CONDITIONS

---

The fire dampers are packed in cardboard boxes or placed on pallets. The fire dampers are protected against damage with plastic film or another cover type. The fire dampers may be transported on any vehicle, which will assure protection from weather. The fire dampers loaded on the vehicle shall be secured from shifting in transit. Before installing the fire dampers, visually inspect each unit. Do not handle the fire damper by holding the connection cable, or put the damper on its control-release mechanism. Do not strike or drop the fire damper. When handling and installing, place the fire damper on casing sides or edges. Store the fire dampers in sheltered rooms protected from outdoor elements. If the fire dampers are stored on the ground, place them on washers to prevent damage.

## 8. MAINTENANCE AND SERVICING

---

The equipment from „Mercor” S.A. requires periodic technical inspection and maintenance at least every 12 months throughout its operating life, i.e. during the warranty and post-warranty period. Inspection and maintenance may only be carried out by the manufacturer or contractors authorised by „Mercor” S.A. to service its products.

The obligation to carry out regular service inspections of fire protection devices results from the § 3 Section 3 of the Regulation by the Minister of Internal Affairs and Administration of 7 June 2010 on fire protection of buildings, other civil structures and areas (Dz. U. 2010, no. 109 item 719).

Do these recommended actions in the inspection intervals:

- Check the electrical connections, especially for all mechanical damage.
- Verify the power supply values for the equipment with the following tolerances:
  - 24 V  $\pm$ 10% for electric actuators
  - 24 V  $\pm$ 2% for electromagnetic triggers
  - 230 V  $\pm$ 10% for electric actuators
  - 230 V  $\pm$ 2% for electromagnetic triggers
- Check the device casing, especially for mechanical damage.
- Check for any obstructions to proper operation of the equipment.

To facilitate the activities under service inspection, servicing and warranty claim response, e.g. visual inspection or repairs, the equipment user/operator shall provide physical access to the equipment by removing thermal insulation, suspended ceiling, and other installations, as required and applicable to warrant unobstructed access.

Inspection ports, e.g. type mcr KRW, are recommended for the equipment installed in ducts.

In the case of roof mounted equipment, provide access to the area (via ladders or elevated platforms).

Refer all matters related to technical inspection, maintenance and servicing of this equipment to the „Mercor” S.A. Service Department, [serwis@mercor.com.pl](mailto:serwis@mercor.com.pl), tel. +48 58 341 42 45 ext. 170, from 8 AM to 4 PM (Mo-Fri).

## 9. WARRANTY TERMS & CONDITIONS

---

1. “MERCOR” SA grants 12 months of warranty for the equipment quality from the date of purchase, unless the sales contract states otherwise.
2. Submit each warranty claim to “MERCOR” SA in 7 days from the date of discovery of a warranty eligible defect
3. Submit warranty claims by calling at: tel. +48 58 341 42 45, by e-mail: [reklamacje@mercor.com.pl](mailto:reklamacje@mercor.com.pl) or by traditional mail: “MERCOR” SA, ul. Grzegorza z Sanoka 2, 80-408 Gdańsk, Poland.
4. If physical defects of equipment are found during the warranty period, “MERCOR” SA warrants and represents to remove them in shortest possible time from serving the written warranty claim with the proof of purchase or sales contract, subject to Item 10.
5. “MERCOR” SA has the right to extend the time of repair if the defect removal is complicated or requires purchase of custom components or spare parts.
6. The warranty liability only covers all defects arising from causes present in the equipment at the date of sale.
7. Defects caused by improper operation or otherwise as listed in Item 10 herein, the buyer / warranty beneficiary will be charged with the costs of their removal.
8. Condition for rectifying defects is that the applicant makes the site/localisation where devices are installed available, in particular, ensuring: the lift in the case of devices mounted at a height above 3m, free access to the rooms where the devices were installed and necessary revisions, dismantling thermal insulation, disassembling suspended ceilings, disassembling other installations, if they prevent free access to the device.
9. If the device can not be repaired at the place of its installation, “MERCOR” SA reserves the necessity of its disassembly, possible delivery to the address indicated by “MERCOR” SA and re-assembly. The cost of this operation lies with the buyer / holder of the guarantee.
10. The warranty does not cover:
  - Any damage or failure of the equipment caused by improper operation, tampering, failure to conduct periodic technical inspection and/or maintenance established in the Operating and Maintenance Manual, section “SERVICING AND MAINTENANCE”.

## **mcr WIP PRO** multi-blade fire damper

---

- Any damage beyond reasonable control of “MERCOR” SA, and specifically: caused by force majeure, such as torrential rainfall, flooding, hurricanes, inundation, lightning strike, power grid overvoltage, explosion, hail, collision with aircraft, fire, avalanche, landslide and indirect damage due to those causes. Torrential rainfall is understood as any rainfall with the effectiveness factor of 4 or higher in accordance with the definition of the Polish Institute of Meteorology and Water Management - National Research Institute (IMGW-PIB). If the effectiveness factor value specified in the preceding sentence cannot be reasonably established, the actual condition and extent of damage shall be considered at the site of their origin as the action of torrential rain. Hurricane is understood as any wind with a minimum speed of 17.5 m/s (and damage shall be recognised as caused by hurricanes if the effects of such weather phenomenon has been found in the direct vicinity of the damaged property).
  - Damage due to failure to immediately report any defect found.
  - Deterioration in the quality of coatings due to natural weathering/ageing.
  - Defects caused by abrasive or aggressive cleaning agents.
  - Damage caused by aggressive external influence, specifically chemical or biological in nature, or when the origin of which is related to the production processing or activity carried out within the facility protected by the equipment or in its direct vicinity.
  - Wearing parts and consumables (e.g. gaskets/seals), unless they have defects of workmanship and/or material.
  - Damage caused by improper transport, handling, unloading and/or storage of the equipment.
  - Damage caused by installation of the equipment in violation of this Operating and Maintenance Manual and/or good construction practice.
  - The equipment and/or parts thereof with removed or damaged nameplate (rating plate) and/or warranty seals.
11. The buyer/warranty rights holder is required to operate the equipment properly and carry out technical inspection and maintenance in accordance with the section “MAINTENANCE AND SERVICING” in the following Operating and Maintenance Manual.
12. This warranty shall be made immediately void and null if:
- The buyer/warranty rights holder modifies the product design without prior authorisation from “MERCOR” SA.
  - Periodic technical inspection and/or maintenance is not carried out per schedule and/or is carried out by unauthorised personnel or service providers not authorised to do so by “MERCOR” SA and/or the equipment has not been properly operated.
  - Unauthorised personnel attempts any intervention in the product outside of the normal operation and maintenance of this equipment.
13. Any circumstances listed in Item 10 will relieve “MERCOR” SA from the obligation of surety.

The relevant provisions of the Polish Civil Code shall apply to all matters not regulated in these Warranty Terms & Conditions.