

TECHNICAL MANUAL

Fire damper type mcr WIP PRO

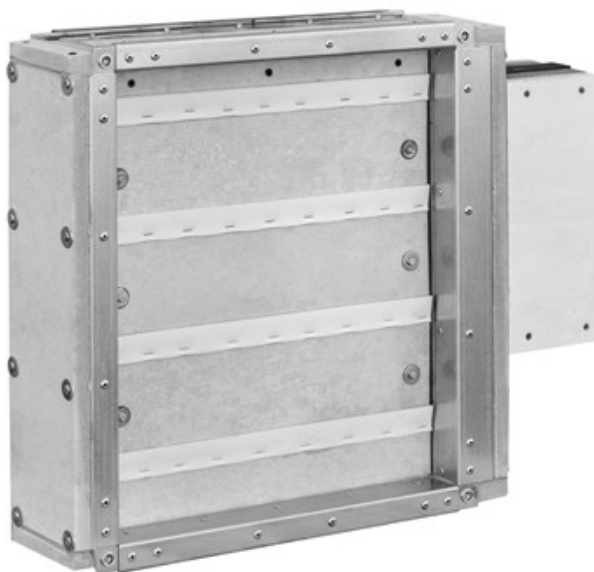

Version WIP PRO 19.06.27.10

CONTENTS:

1. INTRODUCTION	3
2. SUBJECT	3
3. INTENDED USE	3
4. DESIGN & OPERATING PRINCIPLE	4
5. DEVICE IDENTIFICATION	7
6. INSTALLATION	7
6.1. PRE-ASSEMBLY INSPECTION	7
6.2. INSTALLATION OPENING	7
6.3. EMBEDDING	8
6.4. ELECTRICAL CONNECTIONS	15
7. TRANSPORT & STORAGE CONDITIONS	18
8. MAINTENANCE & SERVICING	18
9. WARRANTY TERMS & CONDITIONS	19

Technical Manual designations

- Option available
- Option unavailable

mcr WIP PRO multi-blade fire damper

NOTE

All previous issues of this Technical Manual expire on the date of issue hereof.
 The Technical Manual does not apply to the fire dampers manufactured before its date of issue.

1. INTRODUCTION

The purpose of this Technical Manual is to present the intended use, design, principle of operation, correct installation and operation of the mcr WIP PRO multi-blade fire damper, intended for fire ventilation systems.
 The Manual also includes additional information about the operating and transport conditions, and warranty terms and conditions applicable to the product.

2. SUBJECT

This Manual concerns the entire group of multi-blade fire dampers type mcr WIP PRO. Compliance with the Manual guidelines ensures correct performance of the device in terms of fire protection of rooms as well as safety of the system users.

3. INTENDED USE

Application

Type mcr WIP PRO multi-blade fire dampers may be used as:

- shut-off fire dampers – mcr WIP PRO/S
- shut-off fire dampers for fire ventilation systems – mcr WIP PRO/V
- shut-off fire dampers for mixed fire ventilation systems – mcr WIP PRO/V-M
- transfer fire dampers – mcr WIP PRO/T
- relief fire dampers – mcr WIP PRO/T-G

The dampers cannot be operated in systems exposed to dust, except for when they are included in a special, individually developed program of service and technical inspections.

Fire resistance

Type mcr WIP PRO fire dampers have the following fire resistance ratings:

<input checked="" type="checkbox"/> EI60S	<input checked="" type="checkbox"/> /S	<input checked="" type="checkbox"/> /V	<input checked="" type="checkbox"/> /M	<input type="checkbox"/> /T	<input type="checkbox"/> /G	<input checked="" type="checkbox"/> EI120S	<input checked="" type="checkbox"/> /S	<input checked="" type="checkbox"/> /V	<input checked="" type="checkbox"/> /M	<input type="checkbox"/> /T	<input type="checkbox"/> /G
<input checked="" type="checkbox"/> EI60	<input checked="" type="checkbox"/> /S	<input checked="" type="checkbox"/> /V	<input checked="" type="checkbox"/> /M	<input checked="" type="checkbox"/> /T	<input type="checkbox"/> /G	<input checked="" type="checkbox"/> EI120	<input checked="" type="checkbox"/> /S	<input checked="" type="checkbox"/> /V	<input checked="" type="checkbox"/> /M	<input type="checkbox"/> /T	<input type="checkbox"/> /G
<input checked="" type="checkbox"/> E60S	<input checked="" type="checkbox"/> /S	<input checked="" type="checkbox"/> /V	<input checked="" type="checkbox"/> /M	<input type="checkbox"/> /T	<input type="checkbox"/> /G	<input checked="" type="checkbox"/> E120S	<input checked="" type="checkbox"/> /S	<input checked="" type="checkbox"/> /V	<input checked="" type="checkbox"/> /M	<input type="checkbox"/> /T	<input type="checkbox"/> /G
<input checked="" type="checkbox"/> E60	<input checked="" type="checkbox"/> /S	<input checked="" type="checkbox"/> /V	<input checked="" type="checkbox"/> /M	<input checked="" type="checkbox"/> /T	<input type="checkbox"/> /G	<input checked="" type="checkbox"/> E120	<input checked="" type="checkbox"/> /S	<input checked="" type="checkbox"/> /V	<input checked="" type="checkbox"/> /M	<input type="checkbox"/> /T	<input type="checkbox"/> /G
<input checked="" type="checkbox"/> EI180	<input type="checkbox"/> /S	<input type="checkbox"/> /V	<input type="checkbox"/> /M	<input checked="" type="checkbox"/> /T	<input type="checkbox"/> /G	<input checked="" type="checkbox"/> E180	<input type="checkbox"/> /S	<input type="checkbox"/> /V	<input type="checkbox"/> /M	<input checked="" type="checkbox"/> /T	<input type="checkbox"/> /G

The fire resistance rating depends on application, method and place of installation of the damper.

Versions

Multi-blade fire damper mcr WIP PRO is manufactured in below showed versions:

- Rectangular dampers
- Rectangular dampers with round connections
- Round dampers

Dimension type series

The mcr WIP PRO fire dampers are manufactured in the following size ranges:

Type	mcr WIP PRO /S mcr WIP PRO /V, mcr WIP PRO /V-M	mcr WIP PRO /T	mcr WIP PRO /V mcr WIP PRO /V-M
Width	from 110 to 900 mm	from 110 to 900 mm	from 260 to 1250 mm
Height	from 263 to 1250 mm	from 263 to 1250 mm	from 110 to 1250 mm
Length	135 mm		
Rotation axis	Horizontal	Horizontal/ vertical	Vertical
Max. surface area	1,125 m ²	1,125 m ²	1,56 m ²
Min. surface are	0,029m ²		

4. DESIGN AND OPERATING PRINCIPLE

Design

The mcr WIP PRO multi-blade fire dampers comprise a casing with a rectangular cross-section (depending on the version). Construction of the WIP PRO consist of:

- Casing of the damper, made of galvanized or stainless steel sheet (2 sections divided with fire-retardant board), covered from outside with refractory board and C-shape profiles made of galvanized steel (thickness: 1,25mm); whole casing is reinforced from both sides with corners made of flat steel with thickness: 2 mm
- Damper blades rotating around its own axis. Axis is made from 2 steel pivots - each pivot is placed in a brazen sleeve fastened to the fire damper vertical side wall (H). (each blade is made of 2 refractory boards 20 mm thick, shifted against each other)
- An intumescent gasket and a ventilation gasket, fastened with staples, which is placed on entire length of damper blade
- Release mechanism (actuated by remote control or automatically after activation of the thermal release)
- Vertical side wall of damper with actuator secured with refractory board
- Intumescent and ventilation gaskets (inside of the casing – on the vertical damper side wall “H”)
- A steel shield of actuator in omega letter shape, installed on side “H” of the damper
- Limit profiles made of galvanized or stainless steel, which are restricting movement of the damper blade, placed inside of casing surface. Profiles are covered with ventilation seal.

Operating principle

The operating principle and way of working of the mcr WIP PRO multi-blade fire dampers depend on their application versions:

shut-off fire dampers – mcr WIP PRO/S

In the normal operating position the dampers are open. Closing of the dampers (to the safety position) follows:

- automatically, by tripping the thermoelectric trigger
- manually, by pressing the control button on the thermoelectric trigger
- remotely, by tripping an electric axial actuator with a return spring caused by isolation from the voltage supply
- automatically, by tripping the thermal trigger and the driving spring

shut-off fire dampers for fire ventilation systems – mcr WIP PRO/V

In the normal operating position the dampers are closed. Opening of the dampers (to the safety position) follows:

- remotely, by tripping an electric axial actuator without a return spring, as a result of applying the supply voltage to the actuator in the right manner

shut-off fire dampers for mixed fire ventilation systems – mcr WIP PRO/V-M

In normal operation the dampers are closed or open, depending on the function carried out. Opening / closing of the dampers (to the safety position) follows:

- remotely, by tripping an electric axial actuator without a return spring, as a result of applying the supply voltage to the actuator in the right manner

transfer fire dampers – mcr WIP PRO/T

In the normal operating position, the dampers are open. Closing of the dampers (to the safety position) follows:

- automatically, by tripping the thermoelectric trigger
- manually, by pressing the control button on the thermoelectric trigger
- remotely, by tripping an electric axial actuator with a return spring caused by isolation from the supply voltage
- automatically, by tripping the thermal trigger and the driving spring

relief fire dampers – mcr WIP PRO/T-G

In the normal operating position, the dampers are open or closed, depending on the function carried out.

Opening / closing of the dampers (to the safety position) follows:

- remotely, by tripping an electric axial actuator with a return spring caused by isolation from the supply voltage. The actuator has no thermoelectric trigger.

Proper performance manual check of dampers with electrical actuator for maintenance purposes can be done by using a special hex wrench. The key should be placed in marked socket on the actuator. Thanks to the rotation of the key, damper blade can be placed in desired position. Rotate the wrench slowly, smoothly and carefully. Rotating the wrench too fast or too rapidly may damage the internal actuator gear or the power transmission system.

CAUTION

Never pull directly on the damper blade to open or close the device. This may result in damage of the self-locking driving gear of the damper, and is not covered by warranty.

mcr WIP PRO multi-blade fire damper

Trigger control gears

The following trigger control gears are available for the mcr WIP PRO fire dampers:

Electric actuator:

<input checked="" type="checkbox"/> BF 230-T	<input type="checkbox"/> /S	<input type="checkbox"/> /V	<input type="checkbox"/> /M	<input checked="" type="checkbox"/> /T	<input type="checkbox"/> /G	<input checked="" type="checkbox"/> BE 230	<input type="checkbox"/> /S	<input checked="" type="checkbox"/> /V	<input checked="" type="checkbox"/> /M	<input type="checkbox"/> /T	<input type="checkbox"/> /G
<input type="checkbox"/> BF 24-T (-ST)	<input type="checkbox"/> /S	<input type="checkbox"/> /V	<input type="checkbox"/> /M	<input type="checkbox"/> /T	<input type="checkbox"/> /G	<input type="checkbox"/> BE 24	<input type="checkbox"/> /S	<input type="checkbox"/> /V	<input type="checkbox"/> /M	<input type="checkbox"/> /T	<input type="checkbox"/> /G
<input type="checkbox"/> BF 24-T-TL	<input type="checkbox"/> /S	<input type="checkbox"/> /V	<input type="checkbox"/> /M	<input type="checkbox"/> /T	<input type="checkbox"/> /G	<input type="checkbox"/> BLE 230	<input type="checkbox"/> /S	<input type="checkbox"/> /V	<input type="checkbox"/> /M	<input type="checkbox"/> /T	<input type="checkbox"/> /G
<input type="checkbox"/> BFL 230-T	<input type="checkbox"/> /S	<input type="checkbox"/> /V	<input type="checkbox"/> /M	<input type="checkbox"/> /T	<input type="checkbox"/> /G	<input type="checkbox"/> BLE 24	<input type="checkbox"/> /S	<input type="checkbox"/> /V	<input type="checkbox"/> /M	<input type="checkbox"/> /T	<input type="checkbox"/> /G
<input type="checkbox"/> BFL 24-T (-ST)	<input type="checkbox"/> /S	<input type="checkbox"/> /V	<input type="checkbox"/> /M	<input type="checkbox"/> /T	<input type="checkbox"/> /G	<input checked="" type="checkbox"/> EXBF 230	<input checked="" type="checkbox"/> /S	<input type="checkbox"/> /V	<input type="checkbox"/> /M	<input type="checkbox"/> /T	<input type="checkbox"/> /G
<input type="checkbox"/> BFN 230-T	<input type="checkbox"/> /S	<input type="checkbox"/> /V	<input type="checkbox"/> /M	<input type="checkbox"/> /T	<input type="checkbox"/> /G	<input type="checkbox"/> EXBF 24	<input type="checkbox"/> /S	<input type="checkbox"/> /V	<input type="checkbox"/> /M	<input type="checkbox"/> /T	<input type="checkbox"/> /G
<input type="checkbox"/> BFN 24-T (-ST)	<input type="checkbox"/> /S	<input type="checkbox"/> /V	<input type="checkbox"/> /M	<input type="checkbox"/> /T	<input type="checkbox"/> /G						

Spring gear:

<input type="checkbox"/> RST	<input type="checkbox"/> /S	<input type="checkbox"/> /V	<input type="checkbox"/> /M	<input type="checkbox"/> /T	<input type="checkbox"/> /G	<input checked="" type="checkbox"/> RST/KW1/S	<input checked="" type="checkbox"/> /S	<input type="checkbox"/> /V	<input type="checkbox"/> /M	<input checked="" type="checkbox"/> /T	<input type="checkbox"/> /G
<input checked="" type="checkbox"/> RST/KW1/24P	<input checked="" type="checkbox"/> /S	<input type="checkbox"/> /V	<input type="checkbox"/> /M	<input checked="" type="checkbox"/> /T	<input type="checkbox"/> /G	<input type="checkbox"/> RST/KW1/24I	<input type="checkbox"/> /S	<input type="checkbox"/> /V	<input type="checkbox"/> /M	<input type="checkbox"/> /T	<input type="checkbox"/> /G
<input type="checkbox"/> RST/KW1/230P	<input type="checkbox"/> /S	<input type="checkbox"/> /V	<input type="checkbox"/> /M	<input checked="" type="checkbox"/> /T	<input type="checkbox"/> /G	<input type="checkbox"/> RST/KW1/230I	<input type="checkbox"/> /S	<input type="checkbox"/> /V	<input type="checkbox"/> /M	<input type="checkbox"/> /T	<input type="checkbox"/> /G

Basic dimensions

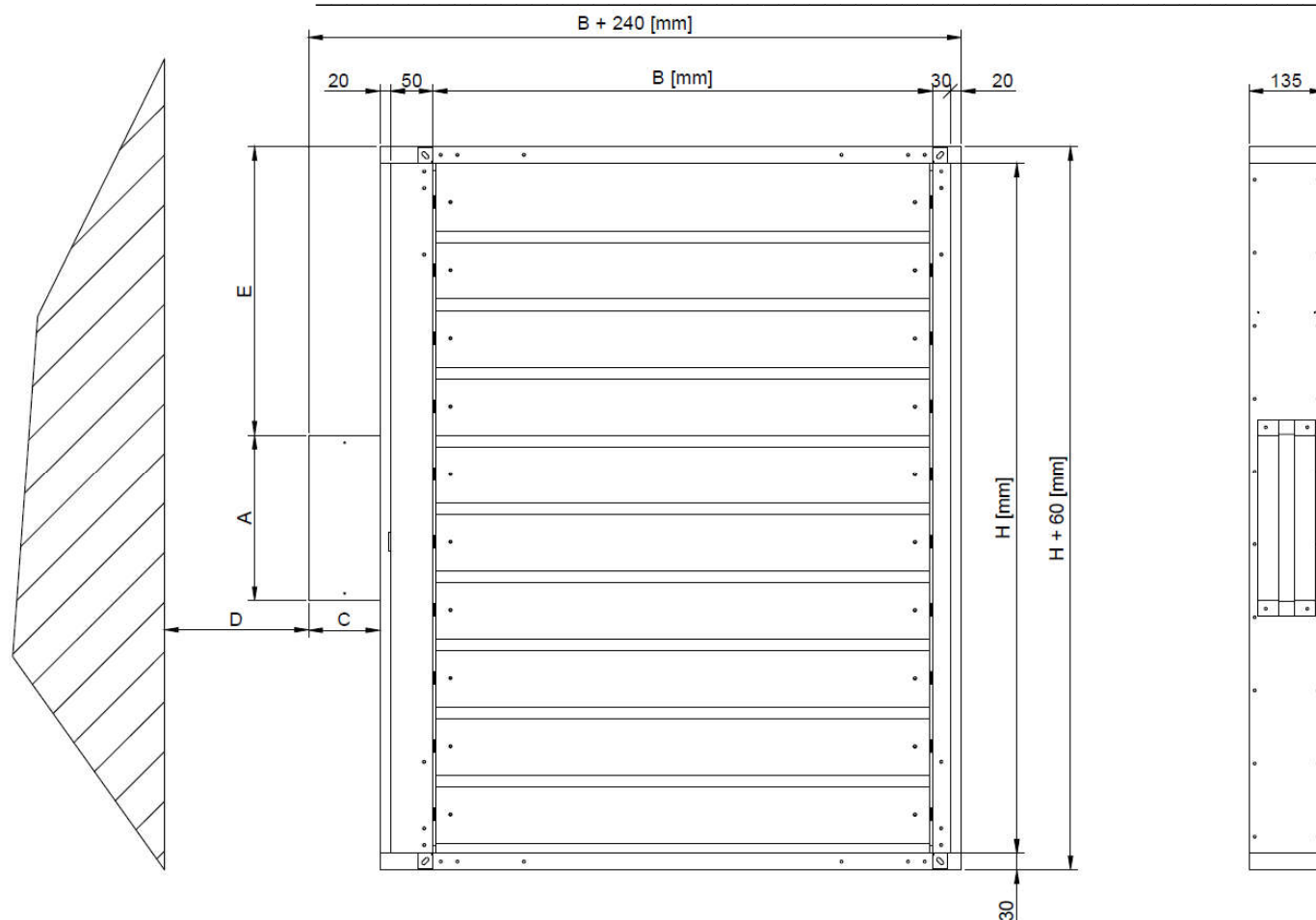

Fire damper mcr WIP PRO with electric actuator BELIMO.

Mechanizm	A	C	D	E
BF, BLF, BFL, BFN, BE, BLE	298	120	75	wzór

mcr WIP PRO multi-blade fire damper

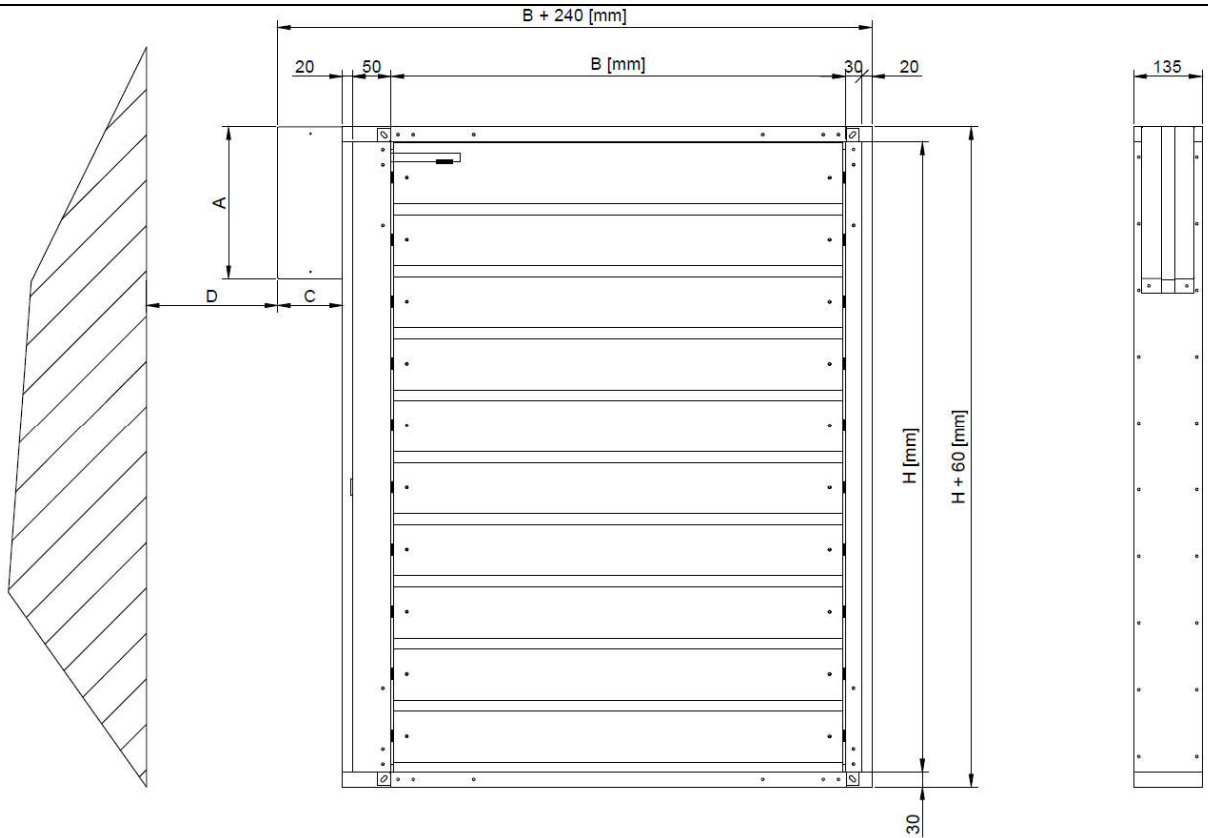

Fire damper mcr WIP PRO with spring gear.

Mechanizm	A	C	D
RST/KW1/S,RST/KW1/24P	298	120	75

5. DEVICE IDENTIFICATION

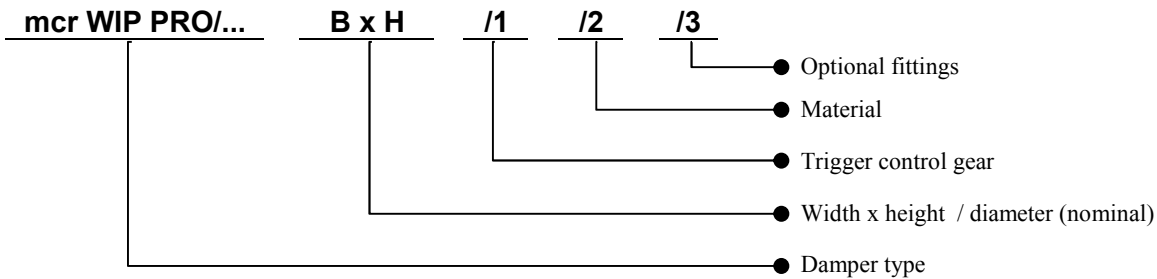

6. INSTALLATION

CAUTION

During the installation of the damper and finishing works with it, there is a need to consider possibility of future access to the device and possibility of disassembly the control-release mechanism in order to perform maintenance or technical review.

The mcr WIP PRO dampers can be installed in the following building partitions (i.e. walls or ceilings):

- masonry concrete walls min. 120 [mm] thick in variants /S, /T, /V, /V-M
- masonry walls made of bricks or blocks min. 120 [mm] thick in variants /S, /T, /V, /V-M
- panel walls min. 125 [mm] thick in variants /S, /T, /V, /V-M
- floor slabs min. 150 [mm] thick in variant /S

*Dampers mounted in the floor slabs, may have a maximum dimension BxH: 1000x1000mm

Additionally, the fire dampers can be installed:

- outside of walls
- in dampers sets (multiple damper sets)

mcr WIP PRO multi-blade fire damper

The mcr WIP PRO shut-off fire dampers may also be installed in partitions with a lower class of fire resistance. In such case the damper fire resistance is equal to the partition fire resistance, if the smoke tightness factor is met. When installing the fire damper in a wall, the thickness of which is narrower than required minimum, increase the thickness at the installation location i.e.: by adding an extra board or other suitable construction material on the damper perimeter.

6.1. PRE-ASSEMBLY INSPECTION

Each fire damper is inspected by the manufacturer before packing and shipping. After unpacking the delivered damper, visually examine it for any damage or casing deformations, which could have occurred during transport.

6.2. INSTALLATION OPENING

The minimum dimensions of the installation opening, which allow correct installation of the mcr WIP PRO damper are:

$$B_o=(B+240)+40[\text{mm}] \quad H_o=(H+60)+40[\text{mm}]$$

Dimension “Z” (distance from the fire damper top edge and the trigger control gear guard box)
 - depends on the dimension H and the applied trigger control gear type:

Gear type	Even number of blades	Odd number of blades
Belimo BF, BLF, BFL, BFN, BE, BLE	$Z [\text{mm}] = (H/2 - 123) + 30$	$Z [\text{mm}] = (H/2 - 61.5) + 30$
RST/KW1/S, RST/KW1/24P	$Z [\text{mm}] = 0$	$Z [\text{mm}] = 0$

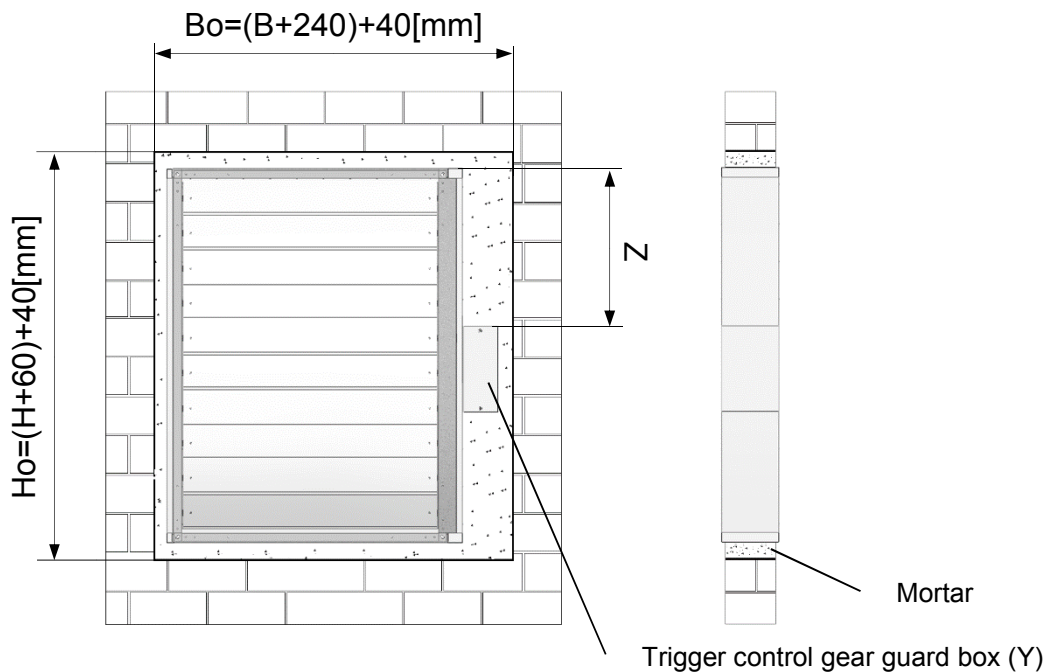

6.3. EMBEDDING / SETTING THE DAMPER

The mcr WIP PRO fire damper will work properly if the damper blade rotation axis is horizontal. The control-release gear may be placed on the right or on the left side of the damper for any direction of air flow.

Before mounting/fixing, place the damper axially in the partition (the wall or ceiling which are separating the fire zones) in earlier prepared/finished mounting opening. Level the device and immobilize it. Install struts for fire dampers with sizes above 700x700 mm. Next, manually run the damper blade to verify that the rotation is correct (i.e. there is no collision with the damper casing parts, etc.). Close the fire damper blade. The blades of fire damper must remain closed until the mortar has cured. Having completed the installation and with the mortar fully cured (if mortar was used), remove the masking covers and the struts, after that open and close the fire damper blades again to verify the correct performance.

In case of installing damper in solid wall – filling the installing gaps with mortar should start from the lowest part of damper, later proceed upward in a way, that will avoid mechanical stress on the trigger control gear guard box with the Y shield.

mcr WIP PRO multi-blade fire damper

Carefully fill the gap between the damper casing and the wall with a proper mortar formula that ensures proper wall and damper fire resistance, and do not let the mortar get into the damper main components (i.e. the trigger control gear, the isolation partition, gaskets and stops). To do this, before installation, the fire damper should be covered with plastic film or other suitable material and remain so until the embedding and finishing is done

When installing the fire damper in a panel wall, fill the space between the damper casing and the wall with mineral wool certified with A1 grade (non-combustible); the mineral wool density and thickness must ensure fire resistance, at the same level or higher than the fire resistance of the wall in which the fire damper is installed. The filled space additionally should be sealed with a proper mortar or putty that has the fire resistance required for the wall.

During fire damper installation in a floor slab, make a frame from Z-bars and set the fire damper in it. Carefully fill the gap between the damper casing and the floor slab with a proper and certified mortar compound that ensures proper wall and damper fire resistance, and do not let the mortar get into the damper actuation components (i.e. the trigger control gear, the damper blade, gaskets and stops). To do this, the fire damper must be covered with plastic film or other suitable material and remain so until the embedding and finishing is done.

In order to ensure the fire resistance of the fire separation element, the damper blades rotation axis cannot be situated outside the wall face.

If the fire partition (wall) thickness is similar to the length of fire damper, it is recommended to install the fire damper in way, where axis of the damper is aligned with the building partition cross section centre. The embedded fire damper must be coaxially connected to the ventilation duct. Protect the fire damper casing from damage, and specifically from straining the casing during the installation process. The fire damper cannot bear the load of the ventilation duct or the ventilation system in which it is installed. Using drills, screws, bolts or other elements that pierce through the casing to the inside of the damper is prohibited. Once connected to the ventilation ducts, re-verify the fire damper performance. During the installation of the mcr WIP PRO fire damper, keep in mind, that the thermal trigger (a fusible link) must not be damaged or exposed to high temperature (from fire, and welding/soldering equipment), which might release it (it is a single use element and is not subjected to warranty replacement). Do not expose the intumescent gaskets installed in the fire damper casing to high temperature. It is impossible to close the damper, when gaskets are swollen. After installation, carefully clean the fire damper and make sure that there is no debris which could obstruct proper performance of the device.

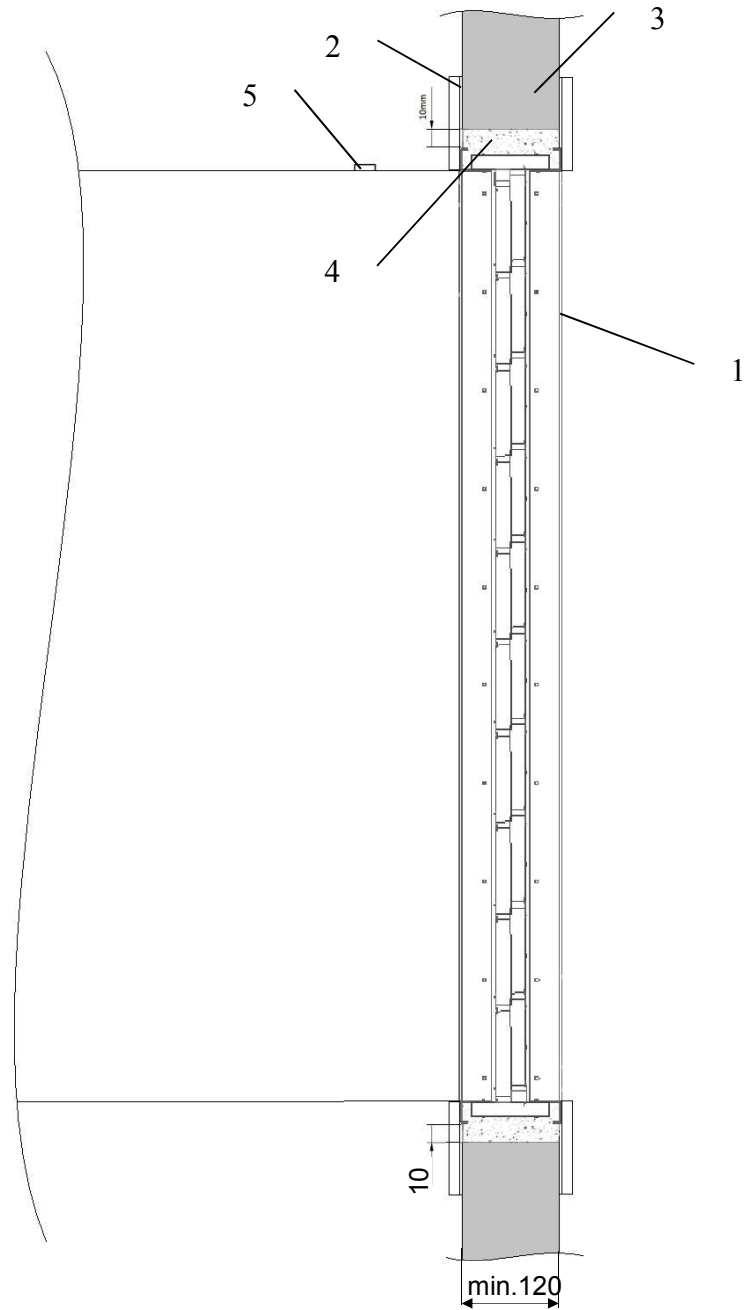

1 - Fire damper
2 - Plasterboard rim, 100x12.5 mm

3 - Solid wall, min. thickness: 120 mm
4 - Mortar

5 - Thermal trigger
(installed in the duct
100 mm from the fire damper)

Fig. mcr WIP PRO fire damper installation example in solid walls made of bricks or stone blocks with a minimum fire resistance rating of EI120. Installation gap: 10 mm.

mcr WIP PRO multi-blade fire damper

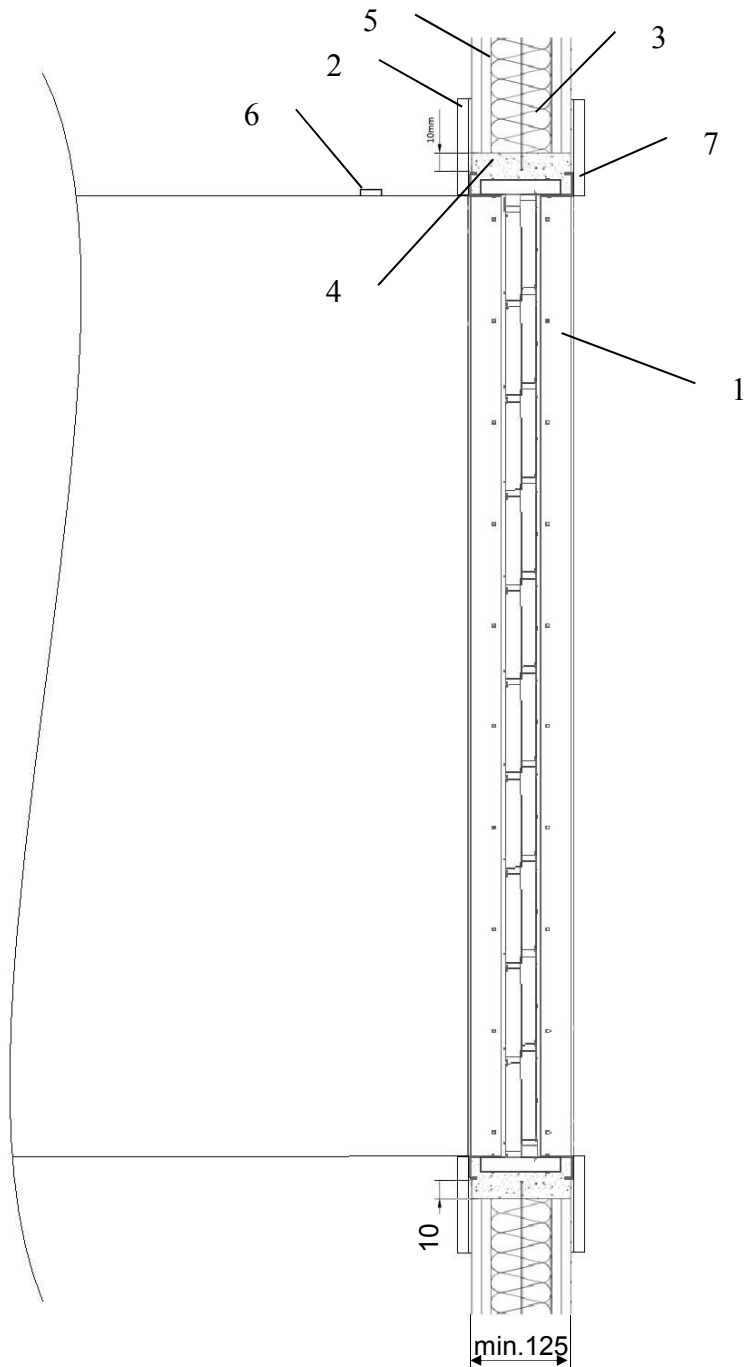

1 - Fire damper
1 - Plasterboard, thickness: 12.5 mm
3 - Mineral wool

4 - Mortar
5 - Structural profile

6 - Thermal trigger (installed in the duct
100 mm from the fire damper)
7 - Plasterboard rim, 100x12.5 mm

Fig. Installation example of the mcr WIP PRO fire damper in a drywall structure with a minimum fire resistance rating of EI120.
Installation gap: 10 mm.

mcr WIP PRO multi-blade fire damper

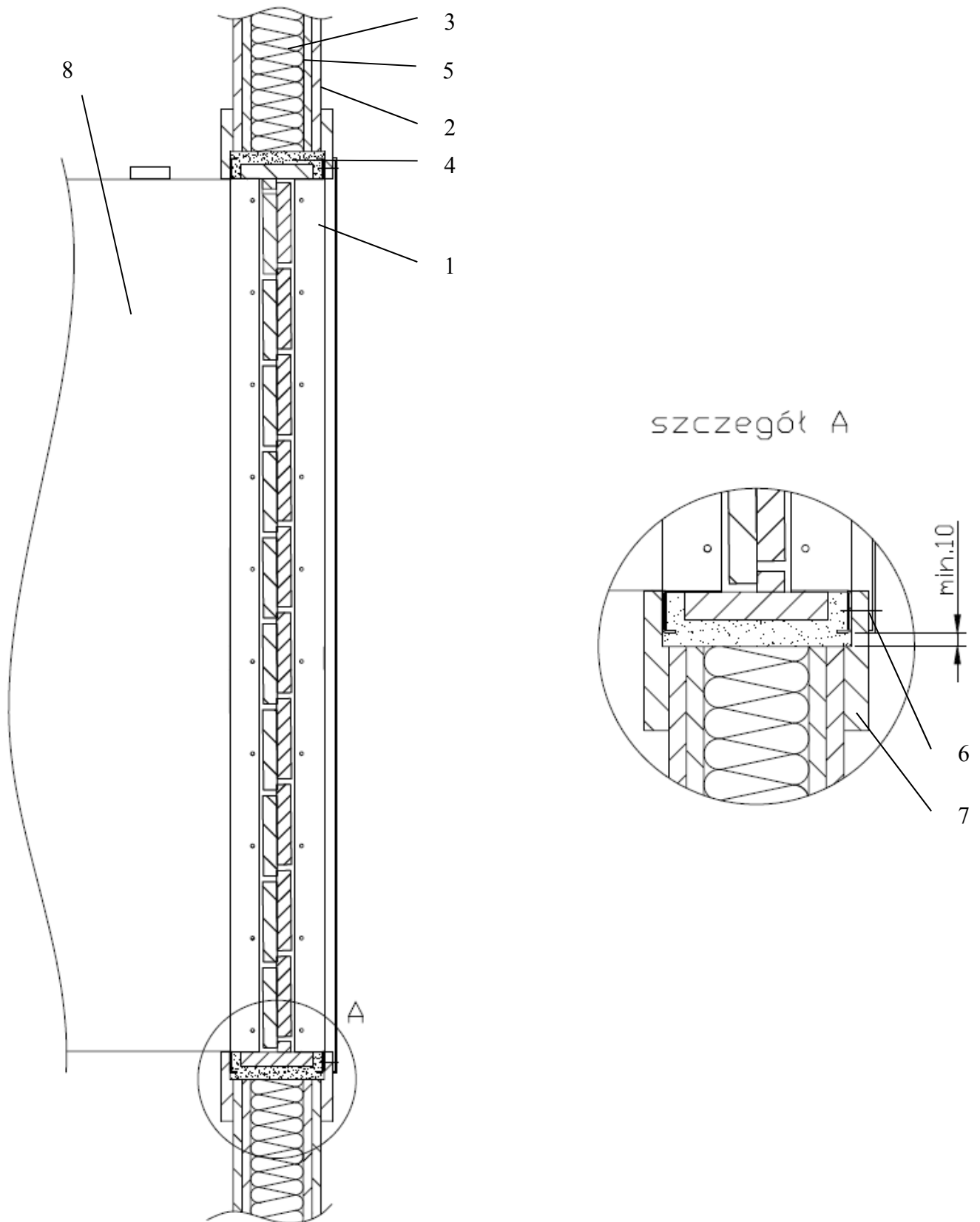

- 1 - Fire damper
- 1 - Plasterboard, thickness: 12.5 mm
- 3 - Mineral wool

- 4 - Mortar
- 5 - Structural profile
- 6 - Masking grid

- 7 - Plasterboard rim, 100x12.5 mm
- 8 - duct

Fig. Installation example of the mcr WIP PRO fire damper in a drywall structure with a minimum fire resistance rating of EI120 with masking grid and duct.
Installation gap: 10 mm.

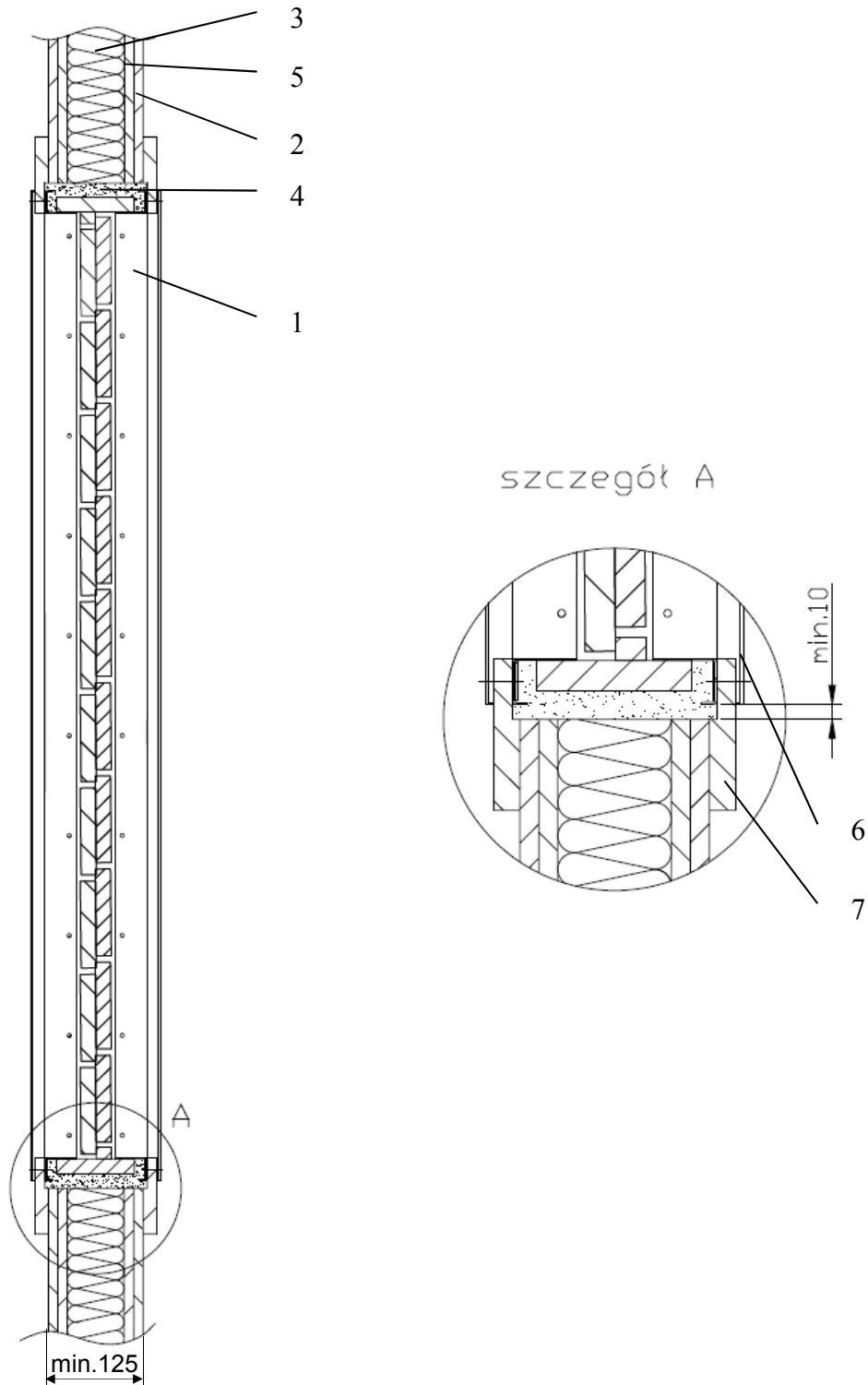

1 - Fire damper
 1 - Plasterboard, thickness: 12.5 mm
 3 - Mineral wool

4 - Mortar
 5 - Structural profile

6 - Masking grid
 7 - Plasterboard rim, 100x12.5 mm

Fig. Installation example of the mcr WIP PRO fire damper in a drywall structure with a minimum fire resistance rating of EI120 with masking grid.
 Installation gap: 10 mm.

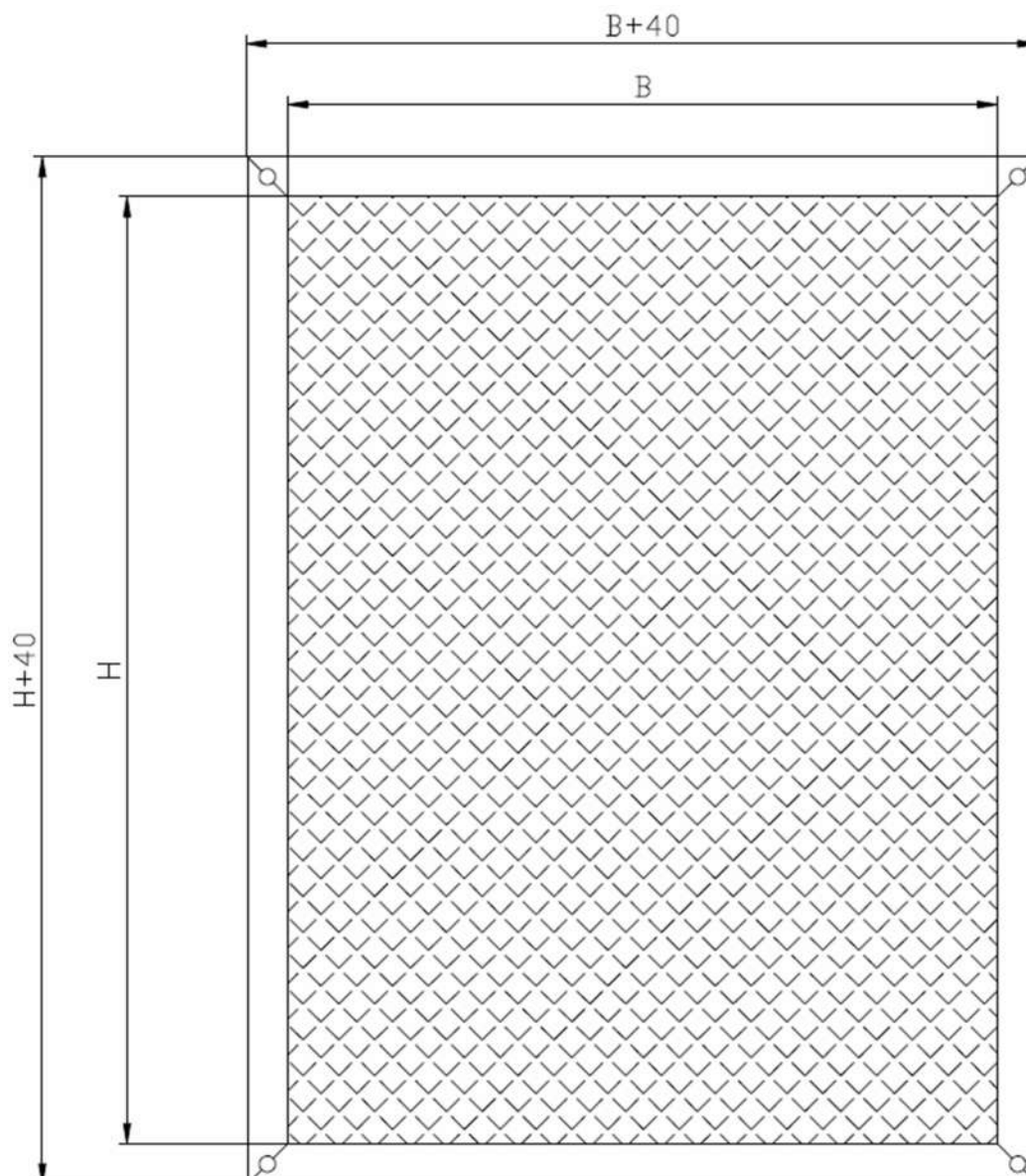
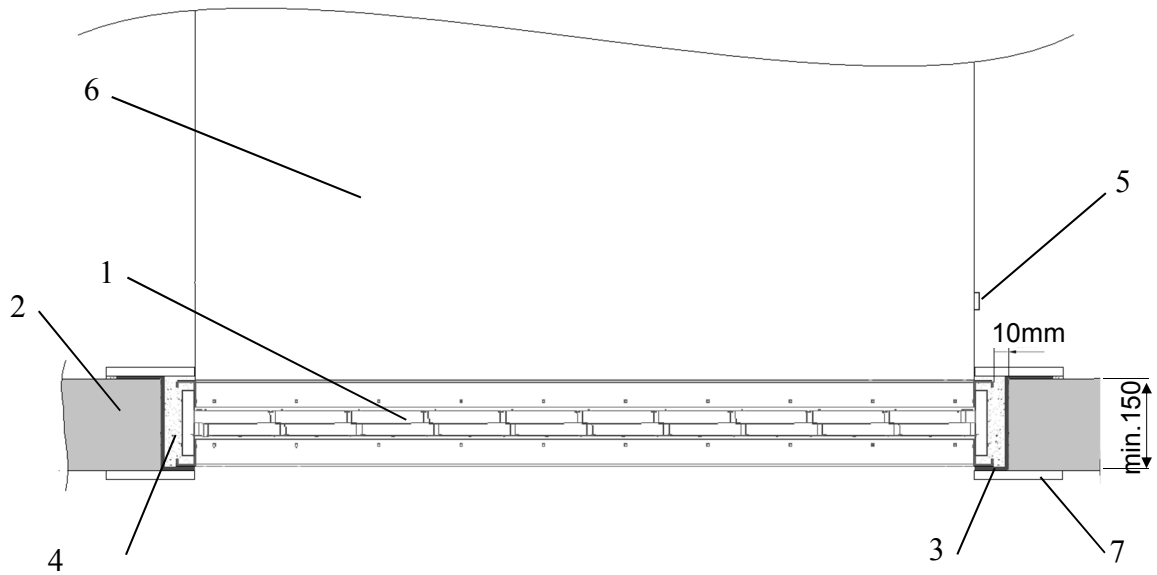

Fig.. Modular masking grill mcr WIP PRO

The masking grid can be supplied as a modular by the damper manufacturer. The solution of system masking grates dedicated in particular to usable spaces with high architectural and functional requirements, allows covering additional damper with any other masking grid while meeting the requirements of mcr WIP PRO fire flap classification.

mcr WIP PRO multi-blade fire damper



1 - Fire damper
 2 - Concrete floor slab, min. thickness: 150 mm
 3 - Mounting Z-bars

4 - Cement mortar
 5 - Thermal trigger (installed in the duct 100 mm from the fire damper)

6 - Steel duct
 7 - Plasterboard rims, 100 mm x 12.5 mm

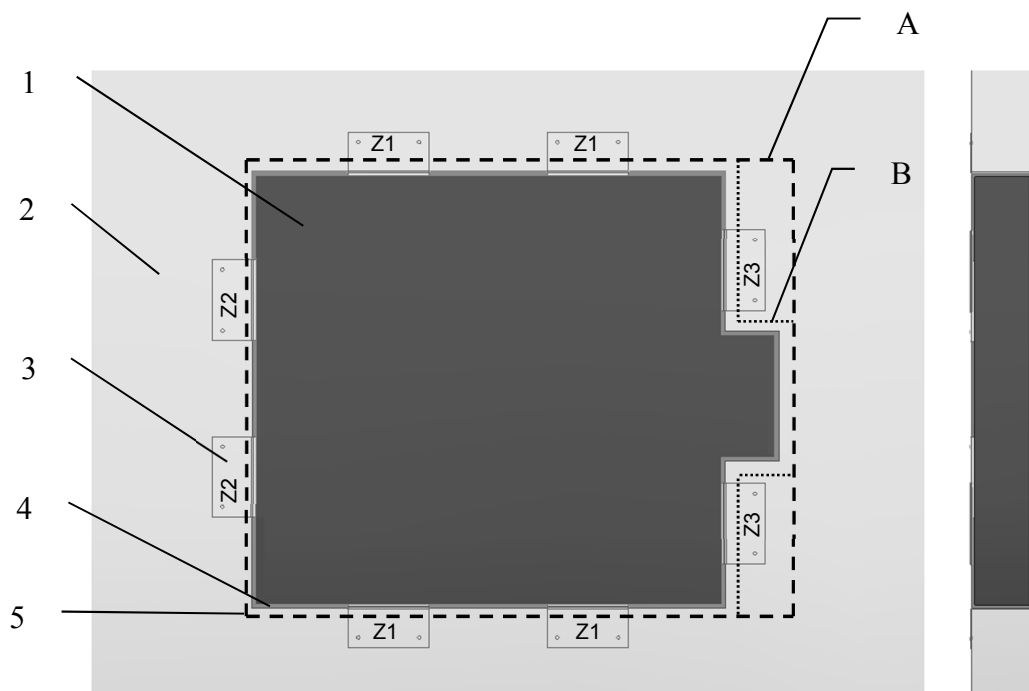

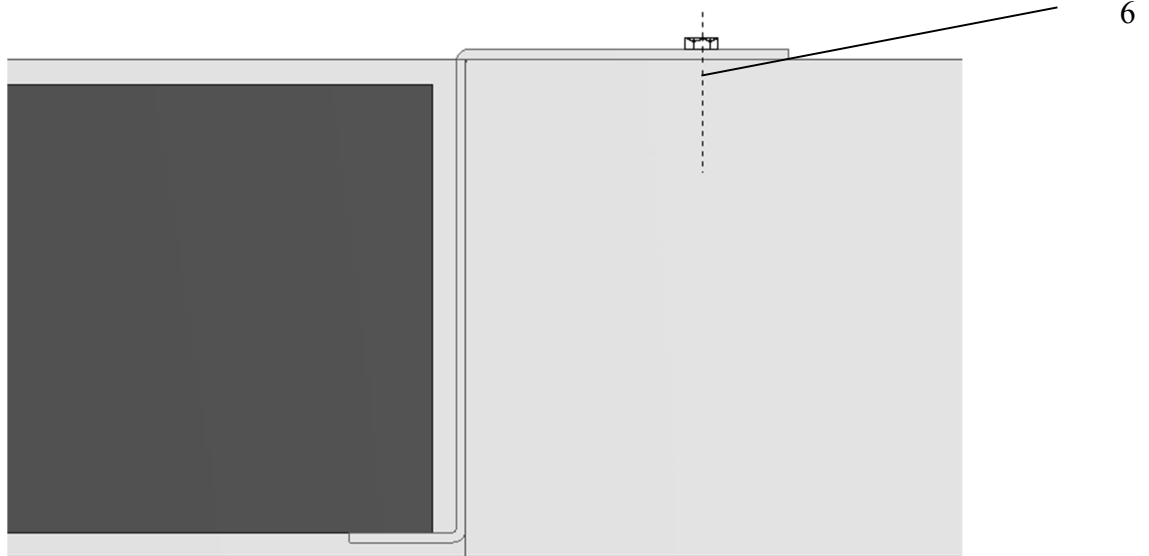

- | | | |
|---|---------------------|---------------------------------|
| 1 - Fire damper | 3 - Mounting Z-bars | 5 - Installation opening |
| 2 - Concrete floor slab, min. thickness: 150 mm | 4 - Cement mortar | 6 - Installation plug, M8x80 mm |

Fig. Example installation of the mcr WIP PRO fire damper in a floor slab, min. thickness 150 mm, min. fire resistance rating: EI120 Installation gap: 10 mm.

The Z-bars are installed from below of the fire damper, Z-bars are selected accordingly to the fire damper frame width.

CAUTION:

The Z-bars are not delivered in package with fire damper set.

If the installation opening is prepared with a place for control-release mechanism (B), use Z3 Z-bars with dimensions as shown in the figure below.

If the installation opening (A) is prepares in rectangle shape, extend the Z3 Z-bars by 120 mm in relation to the dimensions given in the figure below.

mcr WIP PRO multi-blade fire damper

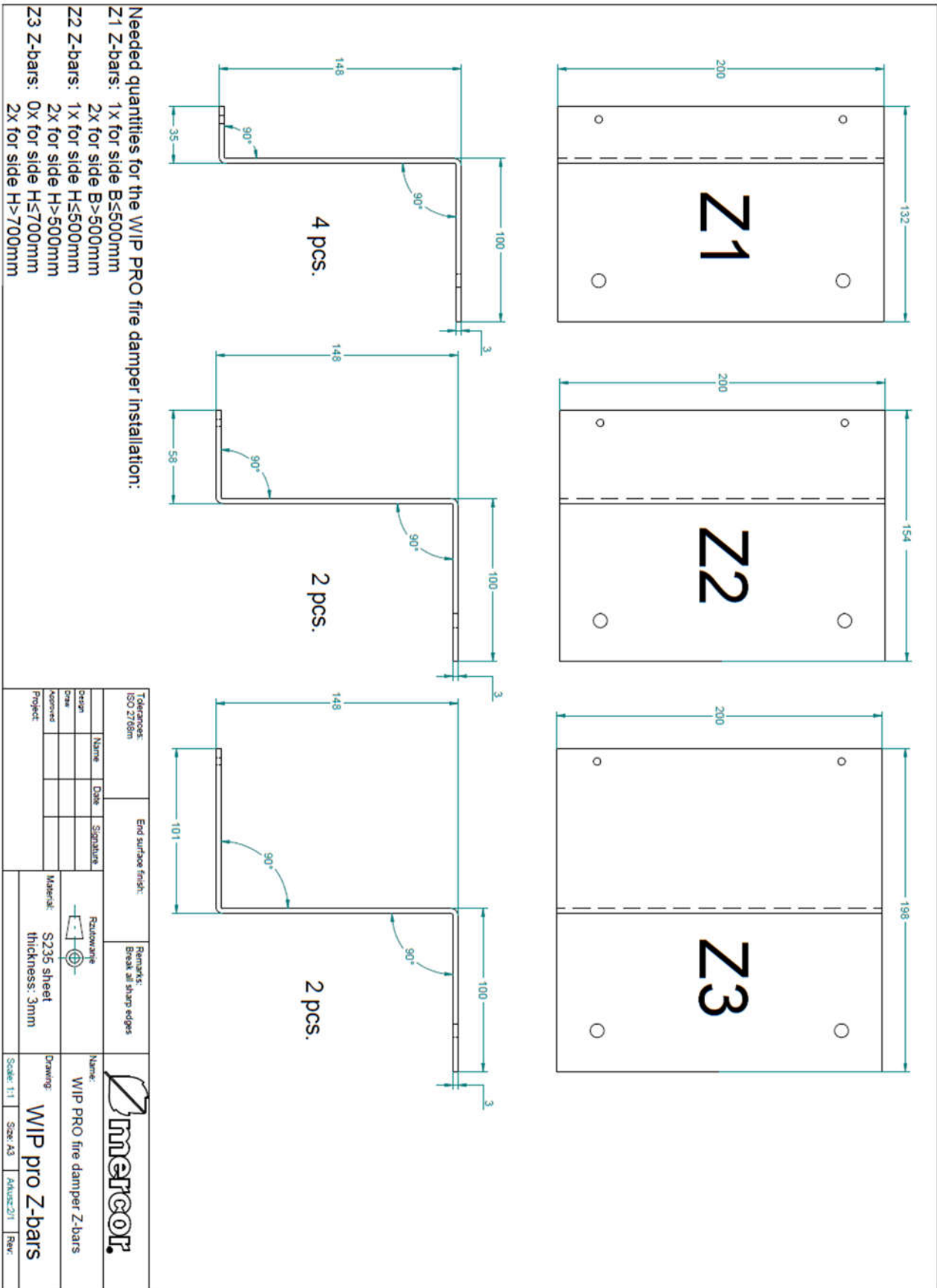
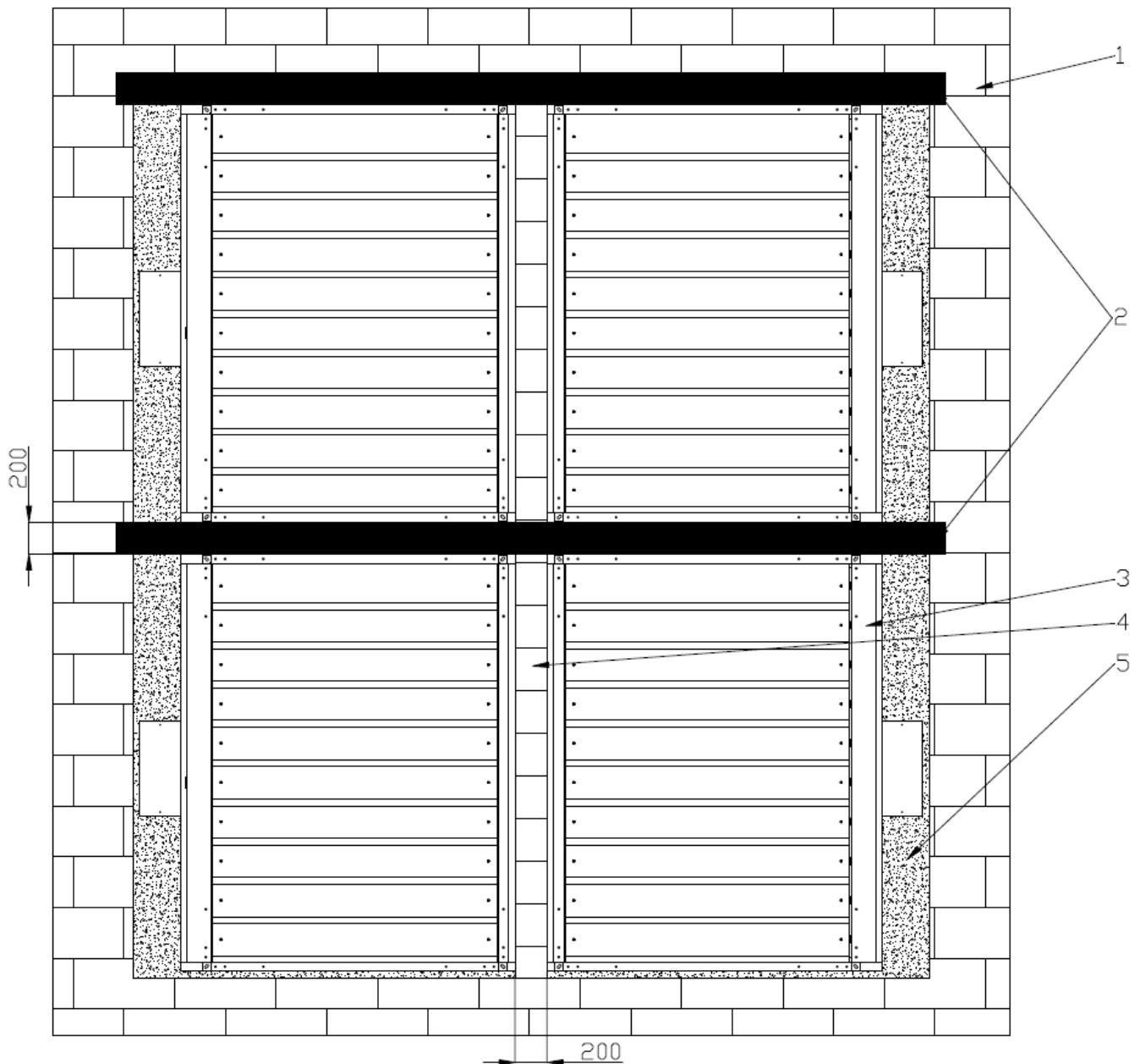

Fig. Mounting Z-bars, installation of the mcr WIP PRO fire damper in a concrete ceiling slab with min. thickness: 150 mm, min. fire resistance rating: R120



- 1 – e.g. a masonry wall
- 2 – A building element with fire resistance equal or higher to the building envelope resistance
- 3 – mcr WIP PRO/ ... fire damper, BxH.

- 4 – A building element with fire resistance equal or higher to the building envelope resistance. For example, a brick wall.
- 5 – e.g. mortar

Installation of the mcr WIP PRO/ ... fire damper as a multiple damper set (a set of 4)

Other configurations of the mcr WIP PRO/ ... dampers modules can be made, consisting of two or more dampers, while maintaining the minimum distances between the dampers according to the drawing above

mcr WIP PRO multi-blade fire damper

For the installation of ventilation ducts are provided the rivet nuts in the corners of the damper. In case of need for additional anchorage of the ventilation duct to the damper, it is possible to use hexagon—type self-tapping screws K type ST 3,5x13mm made of galvanized steel according to DIN 7504. The assembly is possible to the steel frame of the damper in distances shown below:

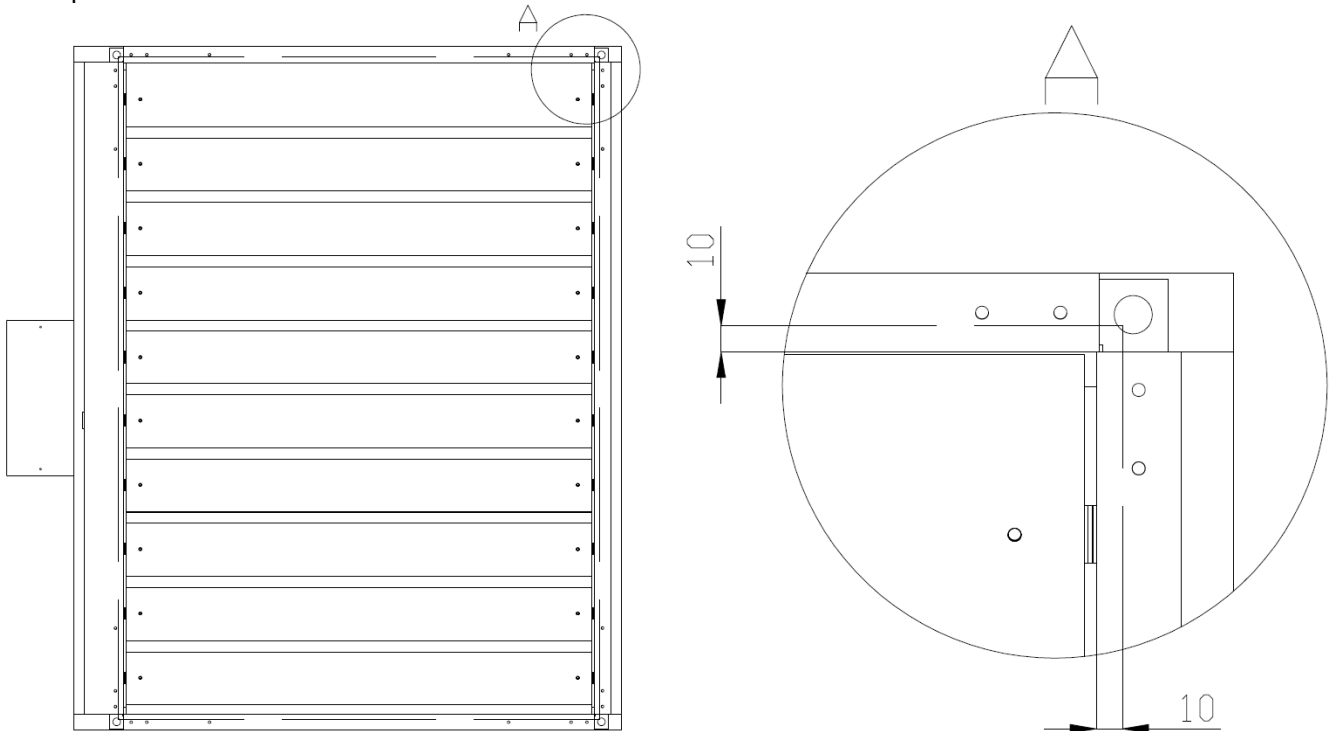

Rys. Installation of ventilation ducts.

mcr WIP PRO multi-blade fire damper

6.4. ELECTRICAL CONNECTIONS

If the damper has control elements or other parts which need to be connected to the electrical grid, they should be connected after correct mounting of fire damper in the wall. Below are showed connection diagrams and basic electrical data of control-release mechanisms with which fire dampers mcr WIP PRO are supplied.

The thermal trigger is supplied with its baseplate for DIY installation. Fasten the thermal trigger with two sheet screws to the device flange or the duct in a location clear of the fire damper blade rotation radius.

Actuator type	Location of the damper blade
- Belimo BFL series - Belimo BFN series - Belimo BF series	Damper blade open – actuator indication: 90° Damper blade closed – actuator indication: 0°
- Belimo BE series - Belimo BLE series	Damper blade open – actuator indication: 0° Damper blade closed – actuator indication: 90°

Technical specifications - Actuators	BF24 (BF24-T)	BF230 (BF230-T)
Power supply	AC 24V 50/60Hz DC 24V	AC 220-240 V 50/60 Hz
Power demand: - for spring tensioning - for spring holding	7 W 2 W	8 W 3 W
Dimensioning (apparent power)	10 VA	11 VA
Protection class	III	II
Ingress protection rating	IP 54	IP 54
Auxiliary circuit breaker:	2 x EPU 3 (0.5) A 250 V	2 x EPU 3 (0.5) A 250 V~
- activation position [degrees]	5°, 80°	5°, 80°
Torque: - motor - spring	18 Nm 12 Nm	18 Nm 12 Nm
Cable connection: - motor (length 0.9 m) - auxiliary circuit breaker	2 x 0.75 mm ² 6 x 0.75 mm ²	2 x 0.75 mm ² 6 x 0.75 mm ²
movement time: (0-90°C) - motor - return spring	120 s ~16 s	120 s ~16 s
Ambient temperature	- 30 ...+50°C	- 30 ...+50°C
Sound pressure level: - motor - return spring	max. 45 dB (A) ~ 63 dB (A)	max. 45 dB (A) ~ 63 dB (A)

Technical specifications - Actuators	BFL 24 (BFL24-T)	BFL230 (BFL230-T)	BFN 24 (BFN24-T)	BFN230 (BFN230-T)
Power supply	AC 24V 50/60Hz DC 24 V	AC 220-240V 50/60 Hz	AC 24V 50/60Hz DC 24V	AC 220-240 V 50/60 Hz
Power demand: - for spring tensioning - for spring holding	2.5 W 0.7 W	3.5 W 1.1 W	4 W 1.4 W	5 W 2.1 W
Dimensioning (apparent power)	4 VA	6.5 VA	6 VA	10 VA
Protection class	III	II	III	II
Ingress protection rating	IP 54	IP 54	IP 54	IP 54
Auxiliary circuit breaker:	2 x SPDT 3 (0.5)A AC 250V	2 x SPDT 3 (0.5)A AC 250V	2 x EPU 3(0.5) A, 250V	2 x EPU 3(0.5) A, 250V~
- activation position [degrees]	5°, 80°	5°, 80°	5°, 80°	5°, 80°
Torque: - motor - spring	4 Nm 3 Nm	4 Nm 3 Nm	9 Nm 7 Nm	9 Nm 7 Nm
Cable connection: - motor (length 0.9 m) - auxiliary circuit breaker	2 x 0.75 mm ² 6 x 0.75 mm ²	2 x 0.75 mm ² 6 x 0.75 mm ²	2 x 0.75 mm ² 6 x 0.75 mm ²	2 x 0.75 mm ² 6 x 0.75 mm ²
movement time: (0-90°) - motor - return spring	<60s ~20s	<60s ~20s	<60s ~20s	<60s ~20s
Operating temperature range	- 30 ...+55°C	- 30 ...+55°C	- 30 ...+55°C	- 30 ...+55°C
Sound pressure level: - motor - return spring	max. 43 dB (A) ~ 62 dB (A)	max. 43 dB (A) ~ 62 dB (A)	max. 55 dB (A) ~ 67 dB (A)	max. 55 dB (A) ~ 67 dB (A)

mcr WIP PRO multi-blade fire damper

Technical specifications - Actuators	BE24	BE230	BLE24	BLE230
Power supply	AC 24 V 50/60 Hz DC 24 V	AC 220-240V 50/60 Hz	AC 24V 50/60Hz DC 24V	AC 230 V 50/60 Hz
Power demand: - for spring tensioning - for spring holding	12 W 0.5 W	8 W 0.5 W	7.5 W 0.5 W	5 W 0.5 W
Dimensioning (apparent power)	18 VA	15 VA	9 VA	12 VA
Protection class	III	II	III	II
Ingress protection rating	IP 54	IP 54	IP 54	IP 54
Auxiliary circuit breaker: - activation position [degrees]	2 x SPDT 6 (1.5) A AC 250 V 5°, 80°	2 x SPDT 6 (1.5) A AC 250 V 5°, 80°	2 x EPU 3 (0.5) A 250 V 5°, 80°	2 x EPU 3 (0.5) A 250 V~ 5°, 80°
Torque: - motor	40 Nm	40 Nm	15 Nm	15 Nm
movement time: (0-90°) - motor	<60s	<60	<30 s	<30 s
Operating temperature range	- 30 ...+50C	- 30 ...+50C	- 30 ...+50°C	- 30 ...+50°C
Sound pressure level: - motor	max. 62 dB (A)	max. 62 dB (A)	max. 62 dB (A)	max. 62 dB (A)

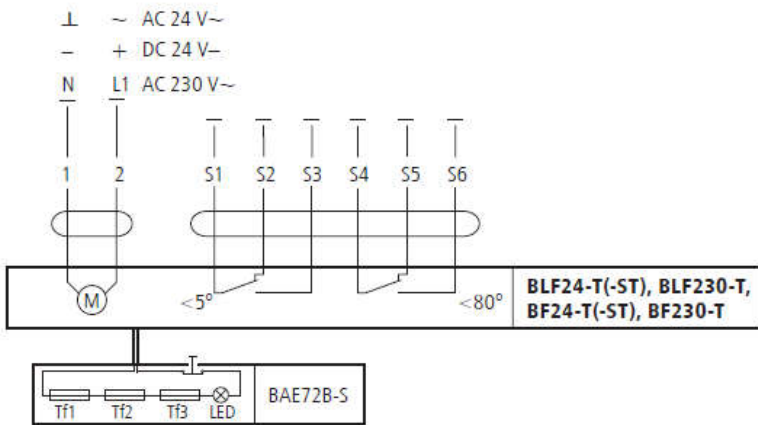

Caution: Connection of 24V via a safety transformer.

The 230 V actuators must be isolated from the power grid with a gap minimum of 3 mm between the switch contacts (when disabled).

It is possible to connect further drives parallel. It is needed to verify the power consumption.

Note:

The locations of the actuator limit switches are shown for the position without the voltage applied.

Connection diagram for the BF24-T, BLF24-T, BF230-T, and BLF230-T actuators

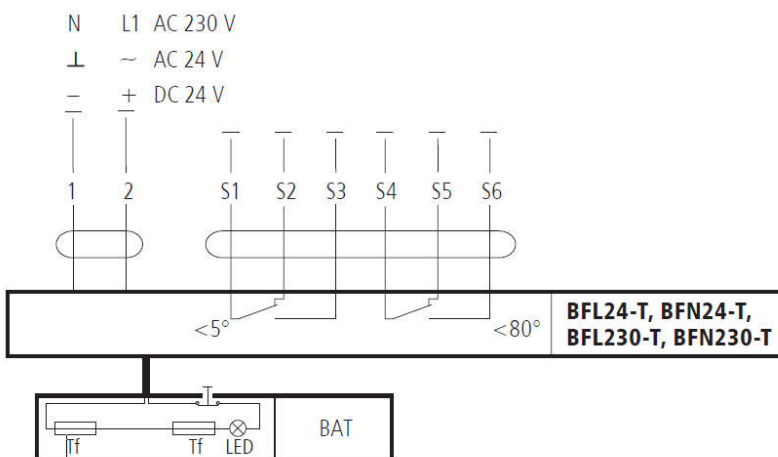

Caution: Connection of 24V via a safety transformer.

The 230 V actuators must be isolated from the power grid with a gap minimum of 3 mm between the switch contacts (when disabled).

It is possible to connect further drives parallel. It is needed to verify the power consumption.

Note:

The locations of the actuator limit switches are shown for the position without the voltage applied.

Connection diagram for the BFL24-T, BFL230-T, BFN24-T, and BFN230-T actuators

mcr WIP PRO multi-blade fire damper

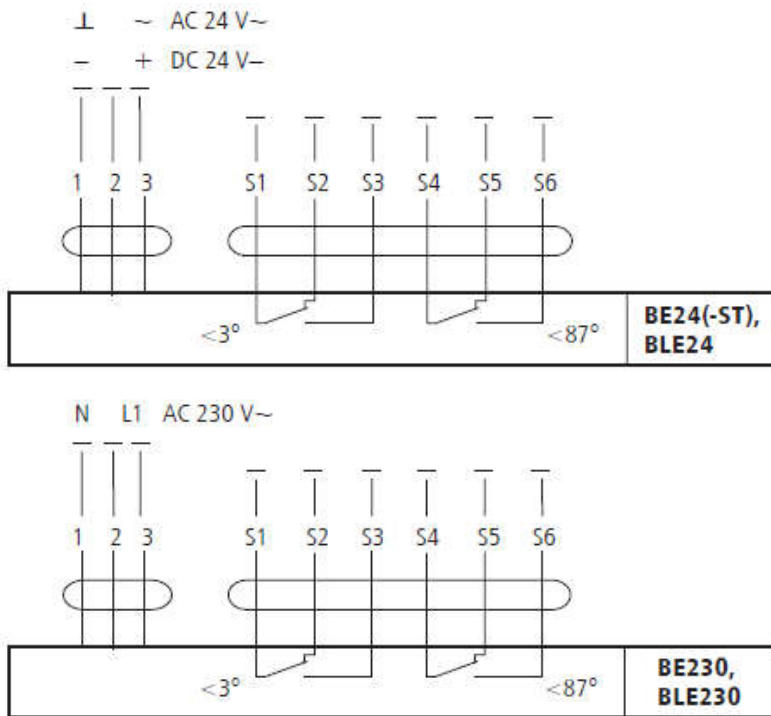

Note:

The actuator operating control requires a three-wire system. The actuator sense of rotation is switched by applying the supply voltage to terminal 2 or 3, depending on the desired direction of rotation.

Caution: Connection of 24V via a safety transformer.

The 230 V actuators must be isolated from the power grid with a gap minimum of 3 mm between the switch contacts (when disabled).

It is possible to connect further drives parallel. It is needed to verify the power consumption.

Note:

The locations of the actuator limit switches are shown for the position without the voltage applied.

Connection diagram for the BE24, BLE24, BE230 and BLE230 actuators

Note:

The BE and BLE actuator operating control requires a three-wire system. The actuator sense of rotation is switched by applying the supply voltage to terminal 2 or 3, depending on the desired sense of rotation. The locations of the limit switches for all types of actuators are showed for the position without the voltage applied. The proper performance of the device with electric actuators requires the rated supply voltage of 24 V $\pm 10\%$ or 230 V $\pm 10\%$, as applicable. Other voltage values may cause operating malfunctions, that are not covered by the product warranty.

RST/KW1 trigger control gear

The RST/KW1/S versions have no electromagnetic release. The gear features integrated limit switches. The electrical connections shall be made by connecting the properly labelled conductors to the electrical supply system. A fusible trigger is installed in the gear.

The RST/KW1/24P version has the electromagnetic release. The gear features integrated limit switches. The electrical connections shall be made by connecting the properly labelled conductors to the electrical supply system. A fusible trigger is installed in the gear. The dampers with the RST/KW1/230I, RST/KW1/230P mechanisms, are supplied with the RST/KW1/24... triggering and control mechanism, together with the 230/24V transformer module type MP230/24.

	RST/KW1/24P (triggered by removal of the supply voltage)
Supply voltage	24 V - 48 V DC
Power demand	1.6W
Holding force	12 daN
Thermal trigger trip point	72°C $\pm 2^\circ$ C
WK1d / WK2d limit switch	NO/NC (switching contact) 5A, 230V AC
Switch trigger	3°, 87°; tolerance: $\pm 2^\circ$
Limit switch operating temperature	-25 ... +85°C
Electrical connection	- release: 0.6 m, 2x0.5 mm ² cable - limit switch: 0.6 m, 6x0.5 mm ² cable
Rotation angle	92°
Movement time	Max. 2s – spring
Sense of rotation	CCW
Gear weight	1.4kg

mcr WIP PRO multi-blade fire damper

RST/KW1 gear power supply:	WK1 limit switch	WK2 limit switch
Wire number: 1-2	Wire number: 3-4 – type NO (normally open)	Wire number: 6-7 – type NO (normally open)
	Wire number: 4-5 – type NC (normally closed)	Wire number: 7-8 – type NC (normally closed)

Caution! - The location of the limit switches is showed for the fire damper in the safety position.

The RST/KW1 trigger control can work with the MP230/24 module. If the MP230/24 module is installed, the fire damper can be powered/controlled with voltage 230 V AC.

The proper performance of the device with electric actuators requires the rated supply voltage of 24 V $\pm 2\%$ or 230 V $\pm 2\%$, as applicable. Other voltage values may cause operating malfunctions, that are not covered by the product warranty.

7. TRANSPORT & STORAGE CONDITIONS

The fire dampers are packed in cardboard boxes or placed on pallets. The fire dampers are protected against damage with plastic film or another cover type. The fire dampers may be transported on any vehicle, which will assure protection from weather. The fire dampers loaded on the vehicle shall be secured from shifting in transit. Before installing the fire dampers, visually inspect each unit. Do not handle the fire damper by holding the connection cable, or put the damper on its control-release mechanism. Do not strike or drop the fire damper. When handling and installing, place the fire damper on casing sides or edges. Store the fire dampers in sheltered rooms protected from outdoor elements. If the fire dampers are stored on the ground, place them on washers to prevent damage.

8. MAINTENANCE AND SERVICING

The equipment from „Mercor” S.A. requires periodic technical inspection and maintenance at least every 12 months throughout its operating life, i.e. during the warranty and post-warranty period. Inspection and maintenance may only be carried out by the manufacturer or contractors authorised by „Mercor” S.A. to service its products.

The obligation to carry out regular service inspections of fire protection devices results from the § 3 Section 3 of the Regulation by the Minister of Internal Affairs and Administration of 7 June 2010 on fire protection of buildings, other civil structures and areas (Dz. U. 2010, no. 109 item 719).

Do these recommended actions in the inspection intervals:

- Check the electrical connections, especially for all mechanical damage.
- Verify the power supply values for the equipment with the following tolerances:
 - 24 V $\pm 10\%$ for electric actuators
 - 24 V $\pm 2\%$ for electromagnetic triggers
 - 230 V $\pm 10\%$ for electric actuators
 - 230 V $\pm 2\%$ for electromagnetic triggers
- Check the device casing, especially for mechanical damage.
- Check for any obstructions to proper operation of the equipment.

To facilitate the activities under service inspection, servicing and warranty claim response, e.g. visual inspection or repairs, the equipment user/operator shall provide physical access to the equipment by removing thermal insulation, suspended ceiling, and other installations, as required and applicable to warrant unobstructed access.

Inspection ports, e.g. type mcr KRW, are recommended for the equipment installed in ducts.

In the case of roof mounted equipment, provide access to the area (via ladders or elevated platforms).

Refer all matters related to technical inspection, maintenance and servicing of this equipment to the „Mercor” S.A. Service Department, serwis@mercor.com.pl, tel. +48 58 341 42 45 ext. 170, fax: +48 58 341 39 85, from 8 AM to 4 PM (Mo-Fri).

9. WARRANTY TERMS & CONDITIONS

1. “MERCOR” SA grants 12 months of warranty for the equipment quality from the date of purchase, unless the sales contract states otherwise.
2. Submit each warranty claim to “MERCOR” SA in 7 days from the date of discovery of a warranty eligible defect
3. Submit warranty claims by calling at: tel. +48 58 341 42 45, by fax: +48 58 341 39 85, by e-mail: reklamacje@mercor.com.pl or by traditional mail: “MERCOR” SA, ul. Grzegorza z Sanoka 2, 80-408 Gdańsk, Poland.

mcr WIP PRO multi-blade fire damper

4. If physical defects of equipment are found during the warranty period, "MERCOR" SA warrants and represents to remove them in shortest possible time from serving the written warranty claim with the proof of purchase or sales contract, subject to Item 10.
5. "MERCOR" SA has the right to extend the time of repair if the defect removal is complicated or requires purchase of custom components or spare parts.
6. The warranty liability only covers all defects arising from causes present in the equipment at the date of sale.
7. Defects caused by improper operation or otherwise as listed in Item 10 herein, the buyer / warranty beneficiary will be charged with the costs of their removal.
8. Condition for rectifying defects is that the applicant makes the site/localisation where devices are installed available, in particular, ensuring: the lift in the case of devices mounted at a height above 3m, free access to the rooms where the devices were installed and necessary revisions, dismantling thermal insulation, disassembling suspended ceilings, disassembling other installations, if they prevent free access to the device.
9. If the device can not be repaired at the place of its installation, "MERCOR" SA reserves the necessity of its disassembly, possible delivery to the address indicated by "MERCOR" SA and re-assembly. The cost of this operation lies with the buyer / holder of the guarantee.
10. The warranty does not cover:
 - Any damage or failure of the equipment caused by improper operation, tampering, failure to conduct periodic technical inspection and/or maintenance established in the Operating and Maintenance Manual, section "SERVICING AND MAINTENANCE".
 - Any damage beyond reasonable control of "MERCOR" SA, and specifically: caused by force majeure, such as torrential rainfall, flooding, hurricanes, inundation, lightning strike, power grid overvoltage, explosion, hail, collision with aircraft, fire, avalanche, landslide and indirect damage due to those causes. Torrential rainfall is understood as any rainfall with the effectiveness factor of 4 or higher in accordance with the definition of the Polish Institute of Meteorology and Water Management - National Research Institute (IMGW-PIB). If the effectiveness factor value specified in the preceding sentence cannot be reasonably established, the actual condition and extent of damage shall be considered at the site of their origin as the action of torrential rain. Hurricane is understood as any wind with a minimum speed of 17.5 m/s (and damage shall be recognised as caused by hurricanes if the effects of such weather phenomenon has been found in the direct vicinity of the damaged property).
 - Damage due to failure to immediately report any defect found.
 - Deterioration in the quality of coatings due to natural weathering/ageing.
 - Defects caused by abrasive or aggressive cleaning agents.
 - Damage caused by aggressive external influence, specifically chemical or biological in nature, or when the origin of which is related to the production processing or activity carried out within the facility protected by the equipment or in its direct vicinity.
 - Wearing parts and consumables (e.g. gaskets/seals), unless they have defects of workmanship and/or material.
 - Damage caused by improper transport, handling, unloading and/or storage of the equipment.
 - Damage caused by installation of the equipment in violation of this Operating and Maintenance Manual and/or good construction practice.
 - The equipment and/or parts thereof with removed or damaged nameplate (rating plate) and/or warranty seals.
11. The buyer/warranty rights holder is required to operate the equipment properly and carry out technical inspection and maintenance in accordance with the section "MAINTENANCE AND SERVICING" in the following Operating and Maintenance Manual.
12. This warranty shall be made immediately void and null if:
 - The buyer/warranty rights holder modifies the product design without prior authorisation from "MERCOR" SA.
 - Periodic technical inspection and/or maintenance is not carried out per schedule and/or is carried out by unauthorised personnel or service providers not authorised to do so by "MERCOR" SA and/or the equipment has not been properly operated.
 - Unauthorised personnel attempts any intervention in the product outside of the normal operation and maintenance of this equipment.
13. Any circumstances listed in Item 10 will relieve "MERCOR" SA from the obligation of surety.

The relevant provisions of the Polish Civil Code shall apply to all matters not regulated in these Warranty Terms & Conditions.