

# **OPERATION AND MAINTENANCE MANUAL (OMM)**

**mcr WIP  
fire damper**



Rev. WIP 19.06.27.17

**CONTENTS:**

1. INTRODUCTION .....	3
2. THE SUBJECT OF THE MANUAL .....	3
3. INTENDED PURPOSE OF THE FIRE DAMPER .....	3
4. DESIGN AND OPERATING PRINCIPLE OF THE FIRE DAMPER .....	4
5. MANUFACTURER'S DESIGNATION OF THE FIRE DAMPER .....	5
6. INSTALLATION OF THE FIRE DAMPER .....	6
6.1. PRE-INSTALLATION INSPECTION .....	6
6.2. INSTALLATION OPENING .....	6
6.3. BUILDING IN THE FIRE DAMPER .....	7
6.4. ELECTRICAL CONNECTIONS .....	12
7. TRANSPORT AND STORAGE CONDITIONS .....	16
8. MAINTENANCE AND SERVICE (REPAIRS) .....	16
9. WARRANTY TERMS AND CONDITIONS .....	16

**Markings used in the OMM**

- Option available
- Option unavailable (except the CE marking)

# mcr WIP type multi-blade fire dampers

## NOTICE

**As at the date of issue of this Operation and Maintenance Manual, previous revisions become invalid. The Operation and Maintenance Manual does not apply to fire dampers manufactured before the date of its issue.**

### 1. INTRODUCTION

The aim of this Operation and Maintenance Manual is to make the user familiar with the intended use, design, operating principle, correct installation and operation of the product.

The OMM also contains additional information on the conditions of use, maintenance and warranty of the product.

### 2. THE SUBJECT OF THE MANUAL

This OMM applies to a whole group of mcr WIP type multi-blade fire dampers. Complying with the recommendations included in the OMM will ensure proper functioning of the fire damper in its purpose of being a fire protection system used in interior spaces as well as the safety of its users.

### 3. INTENDED USE OF THE FIRE DAMPER

#### Use

The mcr WIP type multi-blade (multi-plane) fire dampers may be used as:

- the mcr WIP/S type fire dampers
- the mcr WIP/V type fire dampers for fire ventilation systems
- the mcr WIP/M type fire dampers for mixed-mode fire ventilation systems
- the mcr WIP/T type transfer dampers
- the WIP/T-G type pressure relief dampers

Fire dampers are not designed to work in ventilation systems where there is a risk of them coming into contact with dust-laden air unless they have been covered by a special, tailor-made service and technical inspections programme.

#### Fire resistance

The fire resistance ratings of the mcr WIP type fire dampers are as follows:

■	EI60S	■	/S	■	/V	■	/M	■	/T	■	/T-G	■	EI120S	■	/S	■	/V	■	/M	■	/T	■	/T-G
■	EI60	■	/S	■	/V	■	/M	■	/T	■	/T-G	■	EI120	■	/S	■	/V	■	/M	■	/T	■	/T-G
■	E60S	■	/S	■	/V	■	/M	■	/T	■	/T-G	■	E120S	■	/S	■	/V	■	/M	■	/T	■	/T-G
■	E60	■	/S	■	/V	■	/M	■	/T	■	/T-G	■	E120	■	/S	■	/V	■	/M	■	/T	■	/T-G

The fire ratings depend on the application as well as the manner and place of fire damper installation.

#### Manufacturing versions

The mcr WIP type fire dampers may be manufactured as:

- rectangular fire dampers
- rectangular fire dampers with circular connections
- round fire dampers

#### Series of types of dimensions

The mcr WIP type fire dampers are manufactured in the following dimensions:

width: from 120 to 1,000 mm

height: from 160 to 1,000 mm

rectangular fire dampers' width: 140 mm width of fire

dampers with circular connections: 220 mm

Apart from the standard dimensions, there is a possibility to manufacture fire dampers with any dimensions within the above ranges. The maximum surface area of the mcr WIP type fire damper is 1 m<sup>2</sup>. The minimum surface area of a fire damper is 0.019 m<sup>2</sup>.

### 4. DESIGN AND OPERATING PRINCIPLE OF THE FIRE DAMPER

#### Design

The mcr WIP type fire dampers consist of a housing with a rectangular cross section, movable partition made of an assembly of blades rotating on their axes as well as a release and control mechanism, which is started remotely or automatically (after a thermal release has been actuated). Fire dampers' housings are made of galvanised steel sheet, stainless steel sheet or acid-proof sheet. An integral part of the housing is a flange made of a fire-resistant plate. Each damper blade is made of galvanised steel sheet, stainless steel sheet or acid-proof sheet with a plasterboard inside. On inside of the housing, along the partition axis, an intumescent seal and ventilation seals have been installed. The partition's blades rotate on their axes which are made of steel pins. On the blades, ventilation seals have also been installed. The blades are connected by means of a steel slat that provides the drive. Square and rectangular fire dampers have been equipped with flanged frames allowing to install them in ducts. In the case of a round duct, a square fire damper is manufactured and equipped with a circular flanged connection or a spigot is used.

# mcr WIP type multi-blade fire dampers

## Operation

The operating principle and behaviour of the mcr WIP type fire dampers depends on the version and application:

### ■ mcr WIP/S type fire dampers

These fire dampers remain open during normal operation. They are closed (safety position) in the following ways:

- automatically – by actuation of the thermoelectric release
- manually – by pressing the control button on the thermoelectric release
- remotely – by actuation of the axial electric actuator with a return spring as the supply voltage disappear

### ■ mcr WIP/V type fire dampers for fire ventilation systems

These fire dampers remain closed during normal operation. They are opened (safety position) in the following ways:

- remotely – by actuation of the axial electric actuator without a return spring as the supply voltage is appropriately applied to the actuator

### ■ mcr WIP/M type fire dampers for mixed-mode fire ventilation systems

Depending on the function they serve, these fire dampers remain either closed or open during normal operation. They are opened/closed (safety position) in the following ways:

- remotely – by actuation of the axial electric actuator without a return spring as the supply voltage is appropriately applied to the actuator

### ■ mcr WIP/T type transfer dampers

These dampers remain open or closed during normal operation.

If dampers remain closed during normal operation, opening them (safety position – air transfer) takes places:

- remotely – by actuation of the axial electric actuator with a return spring. The dampers automatically closes after activation of thermoelectric release or after the supply voltage disappears.
- remotely – by actuation of the axial electric actuator without a return spring after applying voltage to the appropriate contact. After widespread of the fire, the damper closes after activation by the building fire protection system, by applying voltage to the appropriate contact of the damper.

If dampers remain open during normal operation (safety position – air transfer), closing them takes places:

- automatically – by actuation of the thermoelectric release
- manually – by pressing the control button on the thermoelectric release
- remotely – by actuation of the axial electric actuator with a return spring as the supply voltage disappears
- remotely – by actuation of the axial electric actuator without a return spring after applying voltage to the appropriate contact.

### □ mcr WIP/T-G type pressure relief dampers

These dampers remain open or closed during operation. Depending on the requirements the close or open takes place by the following ways:

- remotely – by actuation of the axial electric actuator with or without a return spring (applying or withdrawal the voltage). The actuator does not have a thermoelectric release. The work of the actuator is imitated by the system of building fire protection system.

It is possible to check manually the correct functioning of a fire damper with electric actuator for service purposes. To do this, use a special hex key which should be placed in the socket marked on the actuator. Then, by rotating the hex key, the fire damper's partition may be set in the desired position. Bearing in mind to take enough care, rotate the hex key uniformly and slowly. Too fast and violent rotation may cause damage to the internal mechanism of the actuator or the power transmission system.

## NOTIC

### E

**Never try to open or close a fire damper's partition by pulling it directly. Such attempts may cause damage to the self-locking powertrain of a fire damper and this is not covered by warranty. It is recommended that the fire damper were opened and closed when the ventilation system is turned off.**

# mcr WIP type multi-blade fire dampers

## Release and control mechanisms

The release and control mechanism of the mcr WIP type fire dampers may be one of the following:

### Electric actuator:

<input checked="" type="checkbox"/>	BF 230-T	<input type="checkbox"/>	/S	<input type="checkbox"/>	/N	<input type="checkbox"/>	/M	<input checked="" type="checkbox"/>	/T	<input type="checkbox"/>	/T-G	<input checked="" type="checkbox"/>	BE 230	<input type="checkbox"/>	/S	<input checked="" type="checkbox"/>	/N	<input type="checkbox"/>	/M	<input checked="" type="checkbox"/>	/T	<input type="checkbox"/>	/T-G
<input checked="" type="checkbox"/>	BF 24-T (-ST)	<input type="checkbox"/>	/S	<input type="checkbox"/>	/N	<input type="checkbox"/>	/M	<input checked="" type="checkbox"/>	/T	<input type="checkbox"/>	/T-G	<input type="checkbox"/>	BE 24	<input type="checkbox"/>	/S	<input checked="" type="checkbox"/>	/N	<input type="checkbox"/>	/M	<input checked="" type="checkbox"/>	/T	<input type="checkbox"/>	/T-G
<input checked="" type="checkbox"/>	BF 24-T-TL	<input type="checkbox"/>	/S	<input type="checkbox"/>	/N	<input type="checkbox"/>	/M	<input checked="" type="checkbox"/>	/T	<input type="checkbox"/>	/T-G	<input type="checkbox"/>	BLE 230	<input type="checkbox"/>	/S	<input checked="" type="checkbox"/>	/N	<input type="checkbox"/>	/M	<input checked="" type="checkbox"/>	/T	<input type="checkbox"/>	/T-G
<input checked="" type="checkbox"/>	BFL 230-T	<input type="checkbox"/>	/S	<input type="checkbox"/>	/N	<input type="checkbox"/>	/M	<input checked="" type="checkbox"/>	/T	<input type="checkbox"/>	/T-G	<input type="checkbox"/>	BLE 24	<input type="checkbox"/>	/S	<input checked="" type="checkbox"/>	/N	<input type="checkbox"/>	/M	<input checked="" type="checkbox"/>	/T	<input type="checkbox"/>	/T-G
<input checked="" type="checkbox"/>	BFL 24-T (-ST)	<input type="checkbox"/>	/S	<input type="checkbox"/>	/N	<input type="checkbox"/>	/M	<input checked="" type="checkbox"/>	/T	<input type="checkbox"/>	/T-G	<input checked="" type="checkbox"/>	EXBF 230	<input type="checkbox"/>	/S	<input type="checkbox"/>	/N	<input type="checkbox"/>	/M	<input checked="" type="checkbox"/>	/T	<input type="checkbox"/>	/T-G
<input checked="" type="checkbox"/>	BFN 230-T	<input type="checkbox"/>	/S	<input type="checkbox"/>	/N	<input type="checkbox"/>	/M	<input checked="" type="checkbox"/>	/T	<input type="checkbox"/>	/T-G	<input type="checkbox"/>	EXBF 24	<input checked="" type="checkbox"/>	/S	<input type="checkbox"/>	/N	<input type="checkbox"/>	/M	<input checked="" type="checkbox"/>	/T	<input type="checkbox"/>	/T-G
<input checked="" type="checkbox"/>	BFN 24-T (-ST)	<input type="checkbox"/>	/S	<input type="checkbox"/>	/N	<input type="checkbox"/>	/M	<input checked="" type="checkbox"/>	/T	<input type="checkbox"/>	/T-G												

### Spring mechanism:

<input type="checkbox"/>	RST	<input type="checkbox"/>	/S	<input type="checkbox"/>	/N	<input type="checkbox"/>	/M	<input type="checkbox"/>	/T	<input type="checkbox"/>	/T-G	<input type="checkbox"/>	RST/KW1/S	<input type="checkbox"/>	/S	<input type="checkbox"/>	/N	<input type="checkbox"/>	/M	<input type="checkbox"/>	/T	<input type="checkbox"/>	/T-G
<input type="checkbox"/>	RST/KW1/24P	<input type="checkbox"/>	/S	<input type="checkbox"/>	/N	<input type="checkbox"/>	/M	<input type="checkbox"/>	/T	<input type="checkbox"/>	/T-G	<input type="checkbox"/>	RST/KW1/24I	<input type="checkbox"/>	/S	<input type="checkbox"/>	/N	<input type="checkbox"/>	/M	<input type="checkbox"/>	/T	<input type="checkbox"/>	/T-G
<input type="checkbox"/>	RST/KW1/230P	<input type="checkbox"/>	/S	<input type="checkbox"/>	/N	<input type="checkbox"/>	/M	<input type="checkbox"/>	/T	<input type="checkbox"/>	/T-G	<input type="checkbox"/>	RST/KW1/230I	<input type="checkbox"/>	/S	<input type="checkbox"/>	/N	<input type="checkbox"/>	/M	<input type="checkbox"/>	/T	<input type="checkbox"/>	/T-G

## Main dimensions

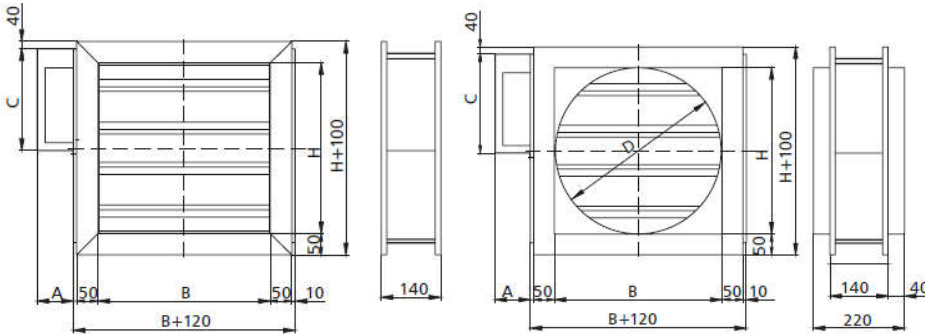

Geat	A	C
BFN	125	325
BFL	125	275
BF	125	325
BF 24TL-ST	125	325
EXBF	175	400
RST-KW1	165	275
BE	125	275
BLE	125	325

*Embed symmetrically with respect to the axis of the wall*

mcr WIP fire damper

## 5. MANUFACTURER'S DESIGNATION OF THE FIRE DAMPER

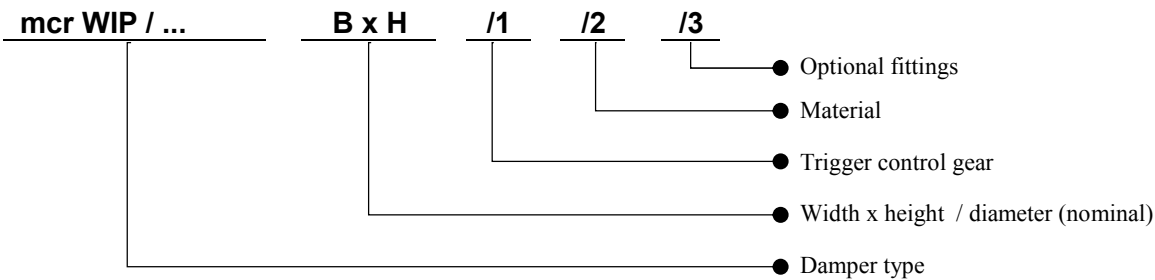

## 6. INSTALLATION OF THE FIRE DAMPER

### NOTICE

During the installation of a fire damper and while conducting finishing work, you should allow for the possibility of later access to the fire damper and removal of the release and control mechanism in order to carry out possible service work and technical inspections.

The mcr WIP fire dampers may be installed in the following space dividing elements (walls or structural floors):

- masonry/concrete walls with a thickness of 120 mm brickwork
- walls or concrete masonry unit walls with a thickness of 120 mm
- walls made of boards with a thickness of 120 mm
- structural floors with a thickness of 150 mm

Additionally, fire dampers may be installed:

- outside walls
- in damper sets (multiple damper sets)

The mcr WIP type fire dampers may also be installed in space dividing elements in buildings that have a lower fire-

## mcr WIP type multi-blade fire dampers

resistance rating. In such cases, fire dampers will have a fire-resistance rating equal to that of a space dividing element, with the condition of smoke leakage rating being satisfied. When installing a fire damper in a given type of wall which is thinner than required, its thickness should be increased along the perimeter of the fire damper, e.g. by installing an additional board or other building element.

**Fire transfer dampers WIP/T and WIP/T-G are assembly including the fire grille, according to the manufacturer guidelines.**

### 6.1. PRE-INSTALLATION INSPECTION

Each fire damper is inspected by the manufacturer before packing and transport. Once the product has been unpacked at the destination, visual inspection should be conducted to check for possible deformations of the housing or fire damper transport damage.

### 6.2. INSTALLATION OPENING

The minimum size of an installation opening necessary for correct installation of the mcr WIP type fire damper is:

$$B_o = (A + B_z + 80) \text{ [mm]} \quad H_o = (H + 180) \text{ [mm]}$$

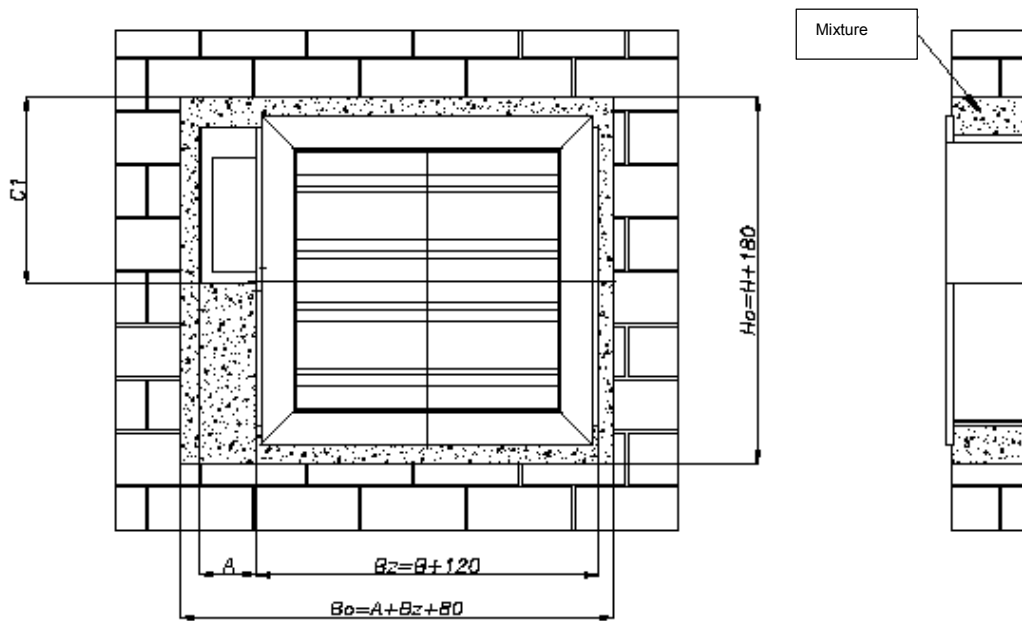

	BF	BFL	BFN	BE	BLE	KW1	EXBF
C1 [mm]	385	335	385	385	335	335	460
A [mm]	125	125	125	125	125	165	175

### 6.3. BUILDING IN (EMBEDDING)

The mcr WIP type fire damper works correctly if the rotation axis of the partition is horizontal. The release and control mechanism may be located on the right or left of a fire damper irrespectively of the air flow direction. Installing a fire damper on its side, i.e. with rotation axes of the partition being vertical, is only permitted when this has been previously made known to the manufacturer at the time of placing the order.

Before building in/embedding, a fire damper should be placed axially in a space dividing element (a wall or structural floor that divides separate fire compartments), i.e. in a previously prepared opening. Next, level and secure the fire damper so that it does not move. For fire dampers with dimensions greater than 700 x 700, a strut should be used. Once the above have been completed, start manually the fire damper's partition (blades assembly), checking if it rotates correctly (it should not touch the housing elements, etc.). Close the fire damper's partition. The gap between the fire damper and the wall should be completely filled with appropriate mixture of your choice (but with all the required certificates), which will provide the desired fire-resistance rating of the wall and the fire damper. Moreover, special attention should be paid to ensure that the mixture does not come into contact with the equipment of the fire damper responsible for its proper operation (release and control mechanism, partition, seals and limiters). For this purpose, it is essential that you put plastic film or other material on the fire damper, which will protect it while masonry and finishing work is being carried out. The partition has to remain closed until the mixture sets. Once it has set, remove the protection and struts. Then, again open and close the fire damper's partition in order to check if it works correctly. In the case of installation of a fire damper in a wall made of boards, the space between the fire damper housing and the wall should be completely filled with A1 class non-flammable (certified) mineral wool. Its density and thickness should ensure fire-resistance not lower than that of the wall in which the fire damper has been installed. Additionally, the filled space should be sealed with an appropriate mixture or mastic having fire-resistance required by the wall. In order to ensure fire-resistance of a fire damper, the depth to which it can be built in should never be

## mcr WIP type multi-blade fire dampers

exceeded, i.e. the rotation axis of the fire damper's blades cannot be outside the wall (off the wall surface). In the case of space dividing elements with a thickness comparable to that of a fire damper, it is recommended that the fire damper be installed in such a manner that its axis divides the thickness of the space dividing element precisely in half. The built-in fire damper has to be coaxially connected to a ventilation duct. When installing a fire damper, be sure that you do not damage its body, and in particular do not subject it to any stress. A fire damper cannot function as a "structural element" of a duct or ventilation system in which it has been installed. It is unacceptable to drill through the fire damper's housing, screw in bolts/screws and other elements that pierce through the housing towards the interior of the fire damper. Having connected the fire damper to a ventilation duct, check again if it works correctly. When installing the mcr WIP type fire dampers, ensure in particular that the thermal release (fusible component) is not damaged. It should not be exposed to high temperature (fire, welders, soldering irons), which causes its actuation (it is a component that has been designed to be used once only and will not be replaced under warranty). Similarly, the intumescent seals installed in the housing of the fire damper should not be exposed to high temperature. Expansion of the seals makes it impossible to close the fire damper. After the installation has been completed, clean thoroughly the fire damper and ensure that no debris has been left inside, as it could affect its correct operation.

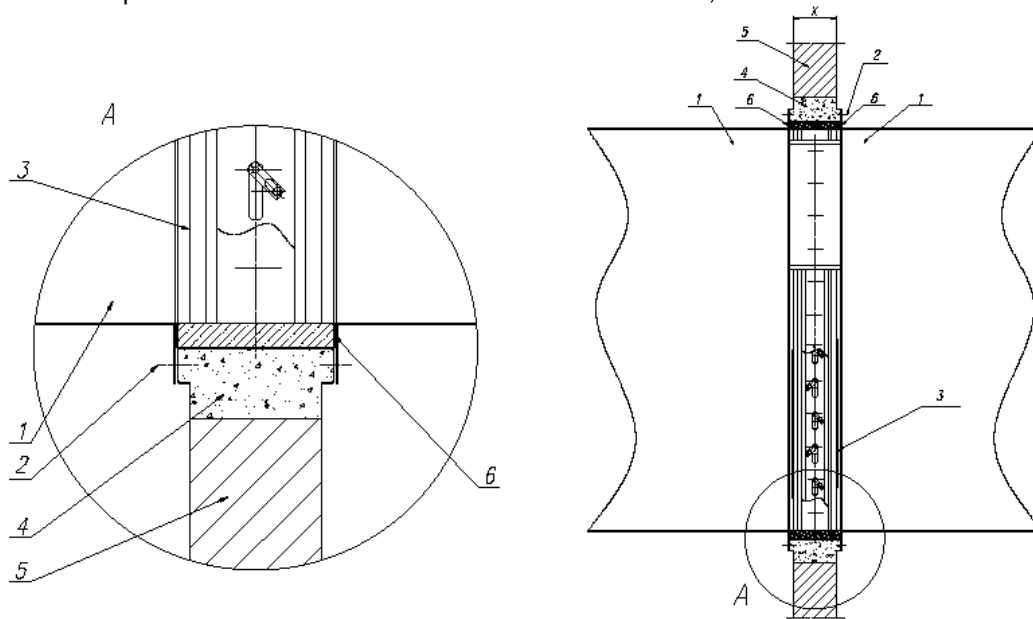

- 1. Ventilation duct
- 2. ST4.2x16 sheet metal screw

- 3. Mcr WIP type fire damper, W x H
- 4. E.g. cement mortar

- 5. Concrete masonry unit or brickwork (with full bricks) wall
- 6. Heat-resistant seal; X – wall thickness

### **Installation of the mcr WIP type fire damper in masonry and concrete walls with ducts**

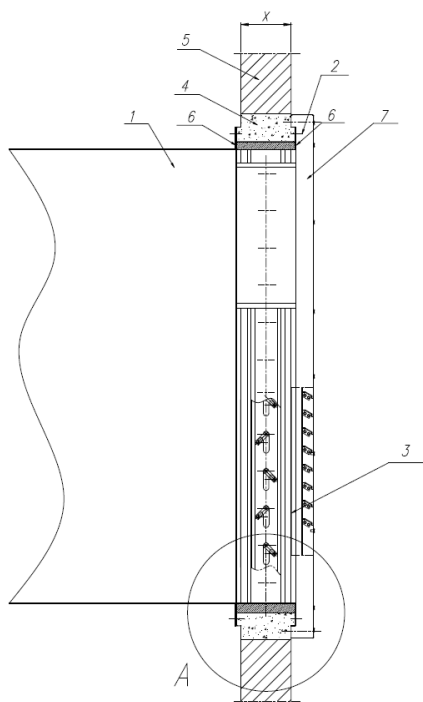

- 1. Ventilation duct
- 2. ST4.2x16 sheet metal screw
- 3. mcr WIP type fire damper, W x H

- 4. E.g. cement mortar
- 5. Concrete masonry unit or brickwork (with full bricks) wall
- 6. Heat-resistant seal;

- 7. Protective grid
- X – wall thickness

### **Installation of the mcr WIP in concrete masonry unit or brickwork (with full bricks) walls with duct and grid**

# mcr WIP type multi-blade fire dampers

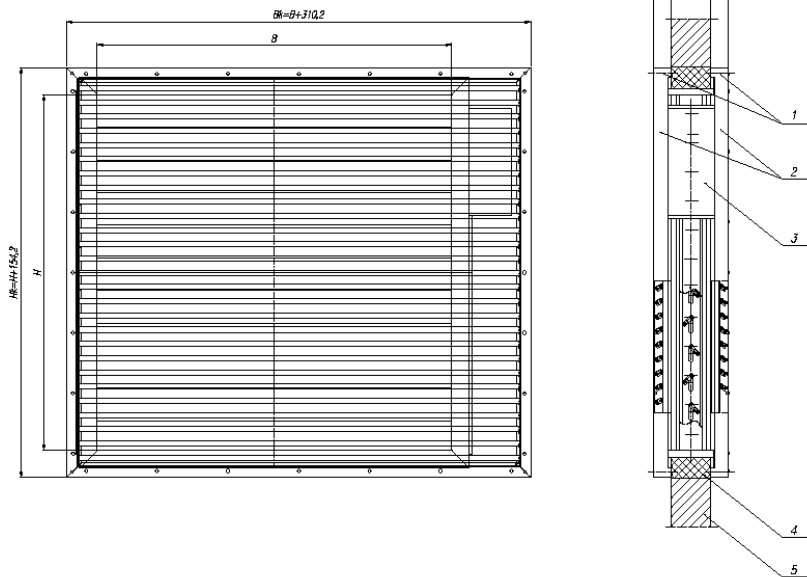

- |                            |                                    |                               |
|----------------------------|------------------------------------|-------------------------------|
| 1. Wall plug with M6 screw | 3. Mcr WIP type fire damper, W x H | 5. Masonry wall               |
| 2. Protective grid         | 4. E.g. cement mortar              | X – wall thickness            |
|                            |                                    | G – protective grid thickness |

## Installation of the protective grid MST for the mcr WIP type fire damper

Protective grid thickness G (shown in the figures) should have 30÷50mm, depending on the thickness of the wall, in

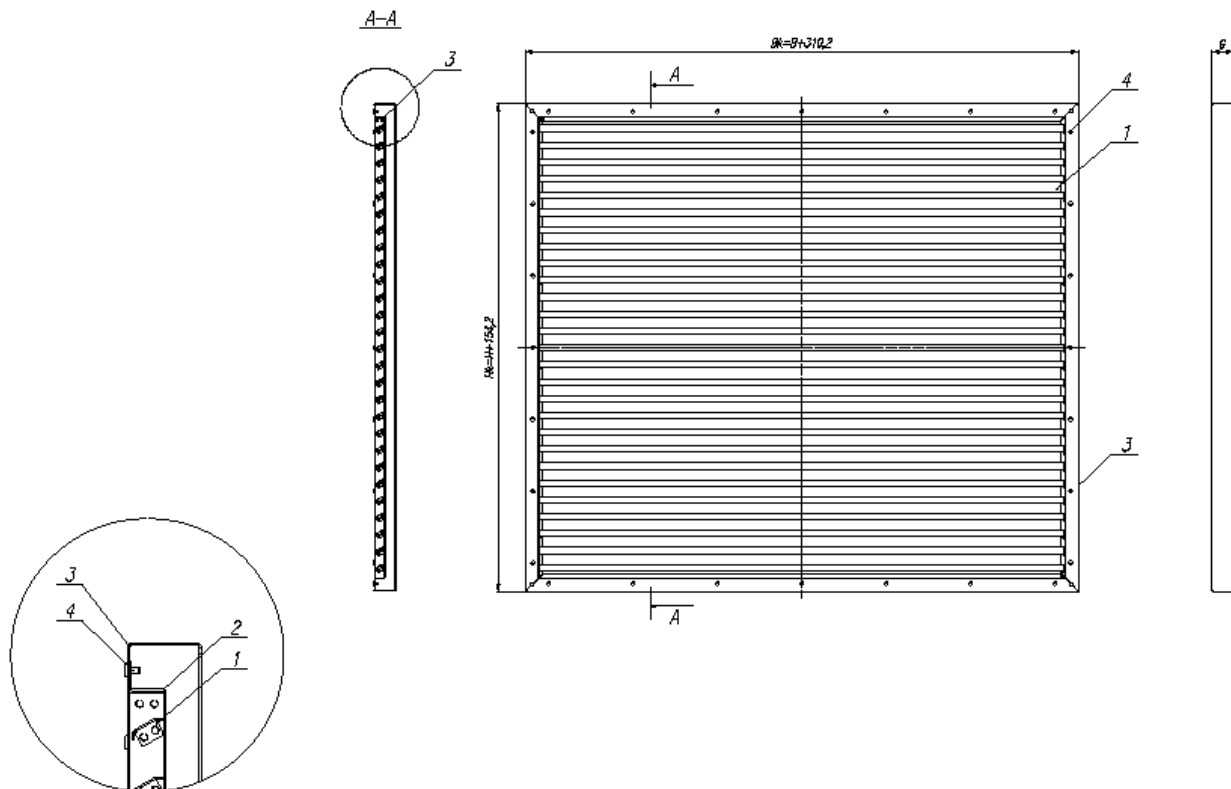

1. Grid blades
2. Internal frame
3. External frame
4. 4.8 diameter rivet

## Modular protective grid MST for the mcr WIP type fire damper

A modular protective grid may be supplied by the manufacturer of the fire damper or made by the person installing the product, provided that the following requirements are met:



# mcr WIP type multi-blade fire dampers

Item no.	Element name	Material	Material thickness depending on the area of application and the size of the grid
1	Grid blades	Galvanised or stainless steel sheet	0,75 mm
2	Internal frame	Galvanised or stainless steel sheet	1,25 mm
3	External frame	Galvanised or stainless steel sheet	1,25 mm

Also, the condition of grid thickness “G” depending on thickness of the wall (in which the fire damper has been installed), has to be ensured.

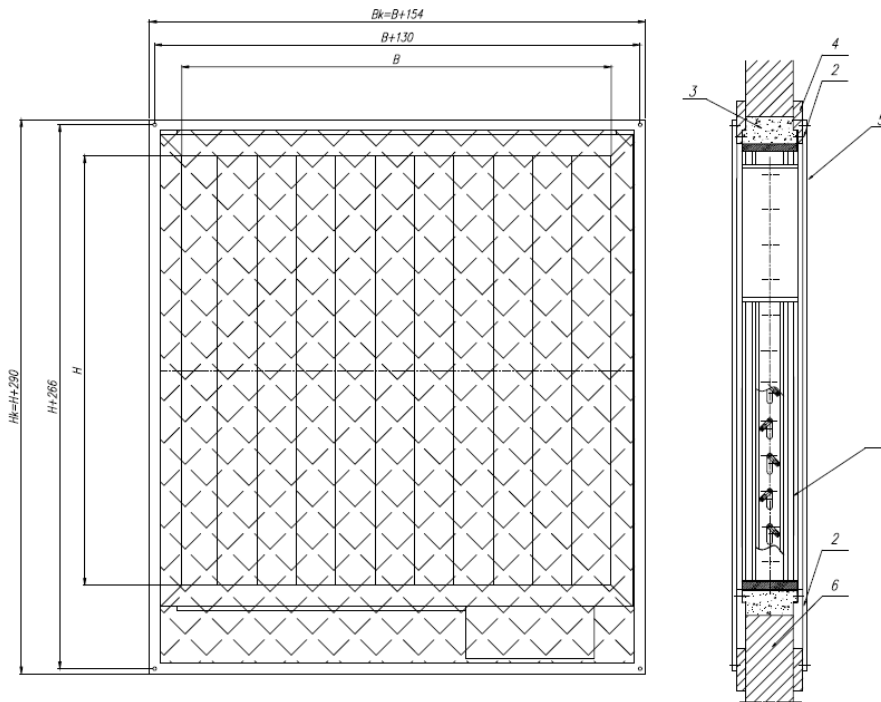

1 – Damper mcr WIP BxH.  
2 - Wall plug with M6 screw

3 – E.g. cement mortar  
4– cardboard gypsum board

5 – Masking grid  
6 – rigid wall

## Installation of the protective grid MWP for the mcr WIP type fire damper

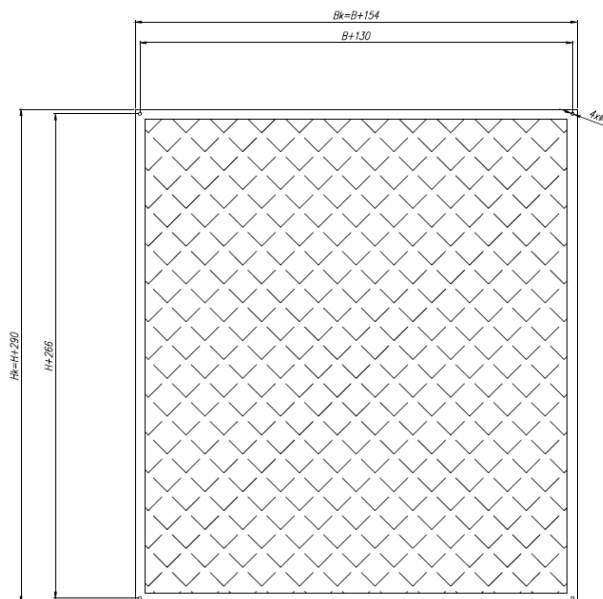

## Modular protective grid MWP for the mcr WIP type fire damper

## mcr WIP type multi-blade fire dampers

The MWP shielding grid can be delivered as a modular one by the damper manufacturer. The solution of system masking grids dedicated in particular to usable spaces with high architectural and functional requirements, allows covering damper with any other masking grid while meeting the requirements of mcr WIP fire damper classification. With wall thicknesses greater than 200mm, system and no system grids can be used directly on the wall.

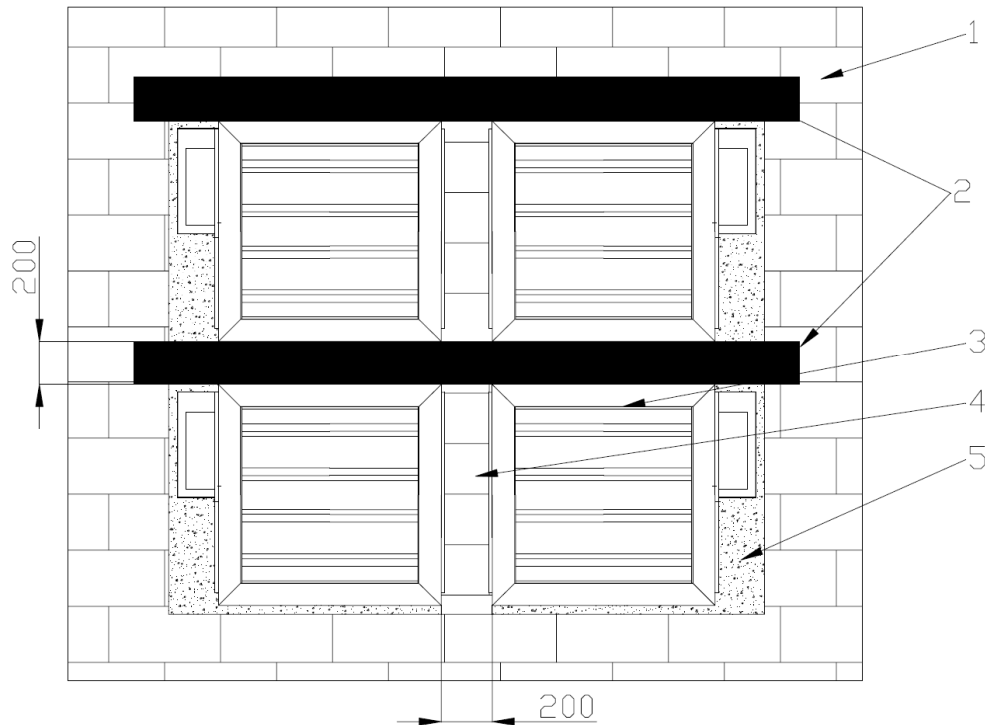

1 – e.g. a masonry wall

2 – A building element with fire resistance equal or higher to the building envelope resistance

3 – mcr FID S/... p/P fire damper, BxH.

4 – A building element with fire resistance equal or higher to the building envelope resistance. For example, a brick wall.

5 – e.g. mortar

### **Installation of the mcr WIP fire damper as a multiple damper set (a set of 4)**

Other configurations of the mcr WIP/... dampers modules can be made, consisting of two or more dampers, while maintaining the minimum distances between the dampers according to the drawing above

## **6.4. ELECTRICAL CONNECTIONS**

Once a fire damper has been correctly installed, it is necessary to connect it to the electrical wiring system (using the wiring system's cables) if the fire damper is equipped with controls or other components that require such connection. Shown below are the wiring diagrams and basic electrical data of the release and control mechanisms supplied together with the mcr WIP type fire dampers.

Thermoelectric tripping device is supplied with a mounting plate for self-assembly. The tripping device shall be fastened with two self-tapping screws to the flange of the fire damper, so as not to block the rotation of the blades.

<b>Actuator type</b>	<b>Position of the fire damper's partition</b>
- Belimo BFL series - Belimo BFN series - Belimo BF series	Partition open – actuator indication 90° Partition closed – actuator indication 0°
- Belimo BE series - Belimo BLE series	Partition open – actuator indication 0° Partition closed – actuator indication 90°

<b>Technical data – actuators</b>	<b>BF24 (BF24-T)</b>	<b>BF230 (BF230-T)</b>
Power supply	AC 24V 50/60Hz DC 24V	AC 220-240V 50/60 Hz
Power demand: – when putting the spring under tension	7 W	8 W
– when in standby	2 W	3 W

## mcr WIP type multi-blade fire dampers

Apparent power	10 VA	11 VA
Protection class	III	II
IP rating	IP 54	IP 54
auxiliary switch:	2 x EPU 3 (0,5) A 250 V	2 x EPU 3 (0,5) A 250 V~
– activation point [degrees]	5°, 80°	5°, 80°
Torque:		
- motor	18 Nm	18 m
- spring	12 Nm	12 Nm
Wire connection:		
– motor (length: 0.9 m)	2 x 0,75 mm <sup>2</sup>	2 x 0,75 mm <sup>2</sup>
– auxiliary switch	6 x 0,75 mm <sup>2</sup>	6 x 0,75 mm <sup>2</sup>
Movement time (0- 90°C):		
- motor	120 s	120 s
- return spring	~16 s	~16 s
Ambient temperature	- 30 ...+50°C	- 30 ...+50°C
Sound pressure level:		
- motor	max 45 dB (A)	max 45 dB (A)
- return spring	~ 63 dB (A)	~ 63 dB (A)

Technical data – actuators	BFL24 (BFL24-T)	BFL230 (BFL230-T)	BFN24 (BFN24-T)	BFN230 (BFN230-T)
Power supply	AC 24 V 50/60 Hz DC 24 V	AC 220–240 V 50/60 Hz	AC 24 V 50/60 Hz DC 24 V	AC 220-240V 50/60 Hz
Power demand:				
– when putting the spring under tension	2.5 W	3,5 W	4 W	5 W
– when in standby	0.7 W	1.1 W	1.4 W	2.1 W
Apparent power	4 VA	6.5 VA	6 VA	10 VA
Protection class	III	II	III	II
IP rating	IP 54	IP 54	IP 54	IP 54
auxiliary switch:	2 x PDT 3(0.5) A AC 250V	2 x PDT 3(0.5) A AC 250V	2 x SPDT 3(0.5) A, 250 V	2 x SPDT 3(0.5) A, 250 V
– activation point [degrees]	5°, 80°	5°, 80°	5°, 80°	5°, 80°
Torque:				
- motor	4 Nm	4 Nm	9 Nm	9 Nm
- spring	3 Nm	3 Nm	7 Nm	7 Nm
Wire connection:				
– motor (length: 0.9 m)	2 x 0.75 mm <sup>2</sup>	2 x 0.75 mm <sup>2</sup>	2 x 0.75 mm <sup>2</sup>	2 x 0.75 mm <sup>2</sup>
– auxiliary switch	6 x 0.75 mm <sup>2</sup>	6 x 0.75 mm <sup>2</sup>	6 x 0.75 mm <sup>2</sup>	6 x 0.75 mm <sup>2</sup>
Movement time (0–90°):				
- motor	60 s	60	60 s	60 s
- return spring	≈ 20 s	≈ 20 s	≈ 20 s	≈ 20 s
Working temperature range	-30 ...+55°C	-30 ...+55°C	-30 ...+55°C	-30 ...+55°C
Sound pressure level:				
- motor	max 43 dB (A)	max 43 dB (A)	max 55 dB (A)	max 55 dB (A)
- spring	~ 62 dB (A)	~ 62 dB (A)	~ 67 dB (A)	~ 67 dB (A)

Technical data – actuators	BE24	BE230	BLE24	BLE230
Power supply	AC 24 V 50/60 Hz DC 24 V	AC 220-240V 50/60 Hz	AC 24V 50/60Hz DC 24V	AC 220-240 50/60 Hz
Power demand:				
– when putting the spring under tension	12 W	8 W	7.5 W	5 W
– when in standby	0,5 W	0,5 W	0,5 W	0,5 W
Apparent power	18 VA	15 VA	9 VA	12 VA
Protection class	III	II	III	II
IP rating	IP 54	IP 54	IP 54	IP 54
auxiliary switch:	2 x SPDT 6 (1,5) A AC 250 V	2 x SPDT 6 (1,5) A AC 250 V	2 x EPU 3 (0,5) A 250 V	2 x EPU 3 (0,5) A 250 V~
– activation point [degrees]	5°, 80°	5°, 80°	5°, 80°	5°, 80°
Torque:				
- motor	40 Nm	40 Nm	15 Nm	15 Nm
Movement time (0–90°):				
– motor	<60s	<60	<30 s	<30 s
Working temperature range	- 30 ...+50C	- 30 ...+50C	- 30 ...+50°C	- 30 ...+50°C
Sound pressure level:				
– motor	max 62 dB (A)	max 62 dB (A)	max 62 dB (A)	max 62 dB (A)

# mcr WIP type multi-blade fire dampers

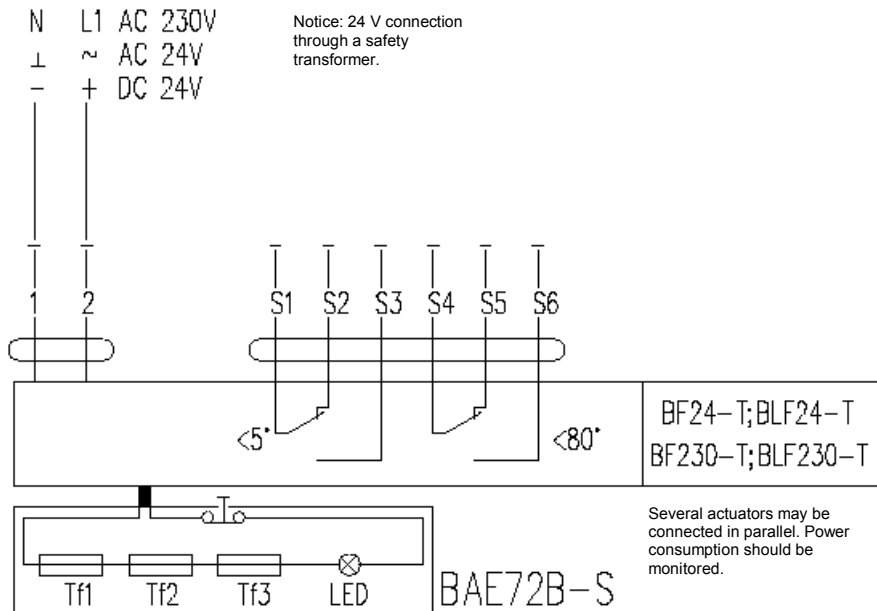

**Wiring diagram for BF24-T, BF230-T actuators**

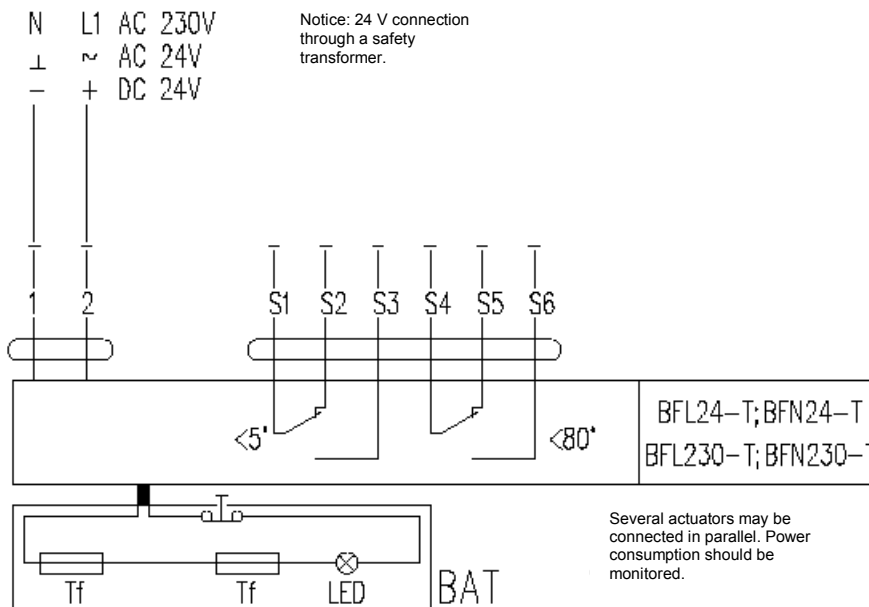

**Wiring diagram for BFL24-T, BFL230-T, BFN24-T and BFN230-T actuators**

# mcr WIP type multi-blade fire dampers

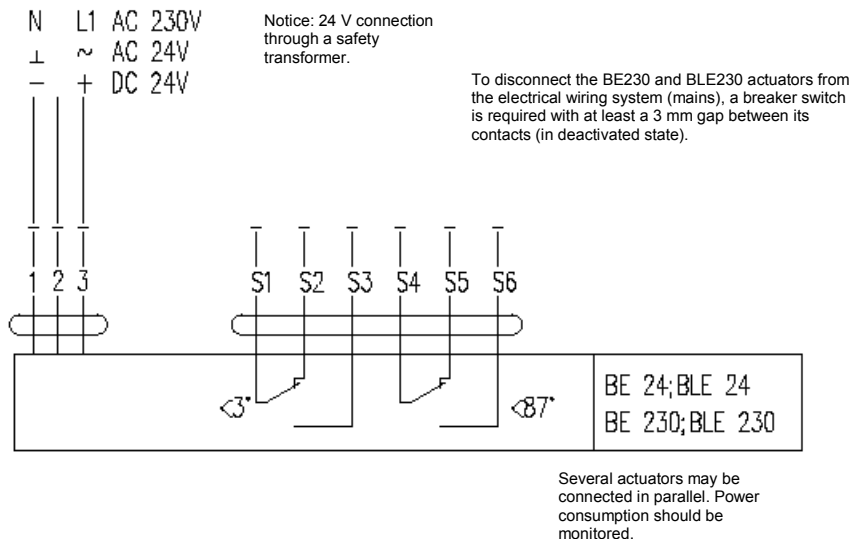

**Wiring diagram for BE24, BLE24, BE230 and BLE230 actuators**

**Notice:**

Controlling the operation of BE and BLE actuators requires connecting them to an electrical wiring system using three-wire cables. The change of rotation direction is effected by applying supply voltage to terminal 2 or 3, depending on the desired direction of rotation. The position of limit switches for all actuator types applies to a potential free position. For proper operation of a device equipped with electrical actuators, it is recommended that the rated voltage housed tolerance of  $24V \pm 10\%$  or  $230V \pm 10\%$ . Power supply devices other than listed above may cause malfunction and will not be covered by the warranty conditions.

Technical data – actuators	EXBF 24	EXBF 230
Power supply	24 V AC $\pm 20\%$ 50/60 Hz / 24 VDC-10/+20%	230 V AC $\pm 14\%$ 50/60 Hz
Power demand:		
- when putting the spring under tension	7 W	8 W
- when in standby	2 W	3 W
Apparent power	10 VA	12.5 VA
IP rating	IP 66	IP 66
Auxiliary switch:	2 x SPDT 6 A (3) max 250 V AC	2 x SPDT 6 A (3) max 250 V AC
- activation point	5°, 80°	5°, 80°
Torque:		
- motor	18 Nm	18 Nm
- spring	12 Nm	12 Nm
Movement time (90°C):		
- motor	150 s	150 s
- return spring	$\approx 20$ s	$\approx 20$ s
Ambient temperature	-20 ...+50°C	-20 ...+50°C

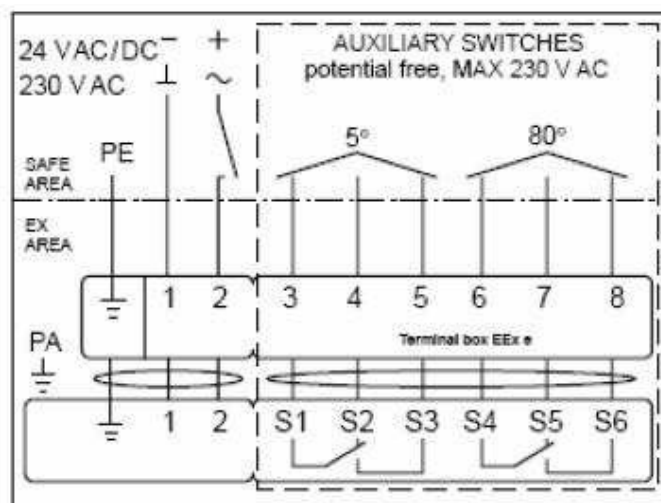

**Wiring diagram for EXBF actuators**

**Caution:**

For proper operation of a device equipped with electrical actuators, it is recommended that the rated voltage

## mcr WIP type multi-blade fire dampers

housed tolerance of  $24V \pm 10\%$  or  $230V \pm 10\%$ . Power supply devices other than listed above may cause malfunction and will not be covered by the warranty conditions.

### RST/KW1 release and control mechanism

In the RST/KW1/S manufacturing version, the limit switches are installed on the mechanism itself. Electrical connection is carried out by connecting the wires (marked accordingly) to the electrical wiring system. The fusible release link is installed on the mechanism itself. The dampers with the RST/KW1/230I, RST/KW1/230P mechanisms, are supplied with the RST/KW1/24... triggering and control mechanism, together with the 230/24V transformer module type MP230/24.

	RST/KW1/S	RST/KW1/24I	RST/KW1/24P	RST/KW1/230I	RST/KW1/230P
Supply voltage	X	24 V – 48 V DC	24 V – 48 V DC	230V AC	230V AC
Power consumption	X	3.5 W	1.6 W	4.5 W	2.5 W
Holding force	X	12 daN	12 daN	12 daN	12 daN
Thermal trigger trip point	72°C $\pm$ 2°C				
WK1d / WK2d limit switch	NO/NC (switching contact) 5A, 230V AC				
Switch trigger	3°, 87° – tolerance: $\pm$ 2°				
Limit switch operating temperature	-25 ...+85°C				
Electrical connection	X	- release: cable 0.6 m, 2x0.5 mm <sup>2</sup> - limit switch: cable 0.6 m, 6x0.5 mm <sup>2</sup>			

KW1 mechanism power supply	WK1 limit switch	WK2 limit switch
Wire no. 1–2	Wire no. 3–4, NO type (normally open)	Wire no. 6-7, NO type (normally open)
	Wire no. 4–5, NC type (normally closed)	Wire no. 7-8, NC type (normally closed)

### Warning! - Location of limit switches of the mechanism was shown for the damper safety position

For proper operation of a device equipped with electrical actuators, it is recommended that the rated voltage housed tolerance of  $24V \pm 2\%$  or  $230V \pm 2\%$ . Power supply devices other than listed above may cause malfunction and will not be covered by the warranty conditions.

### RST release and control mechanism

In the RST manufacturing version, the fusible release link is installed on the fire damper's partition. Mainspring and limit switches are located in the KW1 housing.

### Technical data (limit switches)

WK1 and WK2 limit switches	1 x NO/1 x NC SPDT (changeover switch) 5 A, 230 V AC
Limit switches working temperature	-25 ...+85°C
Housing	plastic

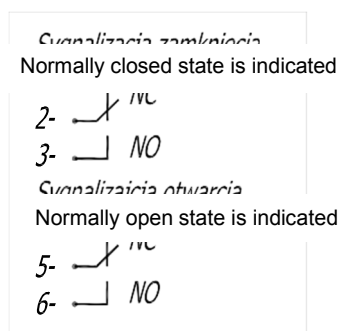

WK1 and WK2 limit switches wiring diagram

## 7. TRANSPORT AND STORAGE CONDITIONS

Fire dampers are packed in cardboard boxes or placed on pallets. They are wrapped in plastic film or other protective material in order to protect them against damage. Fire dampers may be transported using any means of transport, provided that protection against the weather is ensured. Fire dampers placed on transport vehicles should be secured in such a way that they do not move during transport. Before installing fire dampers, conduct visual inspection of each unit. Do not move a fire damper by its connection cable or place it in such a way that its weight is supported on the release and control mechanism. Fire dampers cannot be hit or dropped. When moving and

## mcr WIP type multi-blade fire dampers

installing a fire damper, place it in such a way so that it is supported on its side panels or body edges. Fire dampers should be stored in closed interior spaces which ensure protection against the weather. When fire dampers are stored on the floor, they should be placed on protective supports in order to protect them against damage.

### **8. MAINTENANCE AND SERVICE (REPAIRS)**

Products manufactured by „MERCOR” S.A. should undergo periodic technical inspections and maintenance at least every 12 months throughout their service life, i.e. in the warranty period and later. Inspections and maintenance should be carried out by the manufacturer or by companies authorised to service „MERCOR” S.A.’s products.

The obligation to conduct regular inspections of fire equipment is stipulated in § 3 section 3 of the Regulation of Minister of Internal Affairs and Administration dated 7 June 2010 on the fire protection of buildings, other structures and areas (Dz. U. [Journal of Laws] 2010 No. 109, item 719).

The recommended activities to be carried out between the inspections are as follows:

- check the condition of electrical connections, paying particular attention to mechanical damage;
- Inspections of the condition of the supply voltage for the devices, which allowed the following tolerances:
  - 24V±10% for electric actuators
  - 24V±2% for electromagnetic release mechanism
  - 230V ±10% for electric actuators
  - 230V±2% for electromagnetic release mechanism
- check the condition of the fire damper’s body, paying particular attention to mechanical damage;
- check for causes that could possibly affect the correct operation of the fire damper.

To enable full service inspections as well as servicing, including servicing under the warranty, such as visual inspections and repairs, the user has to ensure physical access to the product, e.g. by removing thermal insulation/suspended ceilings and disassembling other systems if they prevent free access to the product, etc.

In the case of fire dampers installed in ducts, it is recommended to make a service duct such as the mcr KRW type, for instance.

Should fire dampers be installed on a roof, access to the roof should be ensured by providing a ladder or lift.

For matters relating to technical inspections, maintenance and service of our products, please contact the Service Department of „Mercor” S.A. at [serwis@mercor.com.pl](mailto:serwis@mercor.com.pl), phone 058/341 42 45 (extension number 170), fax 058/341 39 85, 8 am–4 pm (Mon–Fri).

### **9. WARRANTY TERMS AND CONDITIONS**

1. “MERCOR” SA grants 12 months of warranty for the equipment quality from the date of purchase, unless the sales contract states otherwise.
2. Submit each warranty claim to “MERCOR” SA in 7 days from the date of discovery of a warranty eligible defect.
3. Submit warranty claims by calling at: tel. +48 58 341 42 45, by fax: +48 58 341 39 85, by e-mail: [reklamacje@mercor.com.pl](mailto:reklamacje@mercor.com.pl) or by traditional mail: “MERCOR” SA, ul. Grzegorza z Sanoka 2, 80-408 Gdańsk, Poland.
4. If physical defects of equipment are found during the warranty period, “MERCOR” SA warrants and represents to remove them in shortest possible time from serving the written warranty claim with the proof of purchase or sales contract, subject to Item 10.
5. “MERCOR” SA has the right to extend the time of repair if the defect removal is complicated or requires purchase of custom components or spare parts.
6. The warranty liability only covers all defects arising from causes present in the equipment at the date of sale.
7. Defects caused by improper operation or otherwise as listed in Item 10 herein, the buyer / warranty beneficiary will be charged with the costs of their removal.
8. Condition for rectifying defects is that the applicant makes the site/localisation where devices are installed available, in particular, ensuring: the lift in the case of devices mounted at a height above 3m, free access to the rooms where the devices were installed and necessary revisions, dismantling thermal insulation, disassembling suspended ceilings, disassembling other installations, if they prevent free access to the device.
9. If the device can not be repaired at the place of its installation, “MERCOR” SA reserves the necessity of its disassembly, possible delivery to the address indicated by “MERCOR” SA and re-assembly. The cost of this operation lies with the buyer / holder of the guarantee.
10. The warranty does not cover:
  - Any damage or failure of the equipment caused by improper operation, tampering, failure to conduct periodic technical inspection and/or maintenance established in the Operating and Maintenance Manual, section “SERVICING AND MAINTENANCE”.
  - Any damage beyond reasonable control of “MERCOR” SA, and specifically: caused by force majeure, such as torrential rainfall, flooding, hurricanes, inundation, lightning strike, power grid overvoltage, explosion, hail, collision with aircraft, fire, avalanche, landslide and indirect damage due to those causes. Torrential rainfall is understood as any rainfall with the effectiveness factor of 4 or higher in accordance with the definition of the Polish Institute of Meteorology and Water Management - National Research Institute (IMGW-PIB). If the effectiveness factor value specified in the preceding sentence cannot be reasonably established, the actual condition and extent of damage shall be considered at the site of their origin as the action of torrential rain. Hurricane is understood as any wind with a minimum speed of 17.5 m/s (and

## mcr WIP type multi-blade fire dampers

damage shall be recognised as caused by hurricanes if the effects of such weather phenomenon has been found in the direct vicinity of the damaged property).

- Damage due to failure to immediately report any defect found.
  - Deterioration in the quality of coatings due to natural weathering/ageing.
  - Defects caused by abrasive or aggressive cleaning agents.
  - Damage caused by aggressive external influence, specifically chemical or biological in nature, or when the origin of which is related to the production processing or activity carried out within the facility protected by the equipment or in its direct vicinity.
  - Wearing parts and consumables (e.g. gaskets/seals), unless they have defects of workmanship and/or material.
  - Damage caused by improper transport, handling, unloading and/or storage of the equipment.
  - Damage caused by installation of the equipment in violation of this Operating and Maintenance Manual and/or good construction practice.
  - The equipment and/or parts thereof with removed or damaged nameplate (rating plate) and/or warranty seals.
11. The buyer/warranty rights holder is required to operate the equipment properly and carry out technical inspection and maintenance in accordance with the section "MAINTENANCE AND SERVICING" in the following Operating and Maintenance Manual.
  12. This warranty shall be made immediately void and null if:
    - The buyer/warranty rights holder modifies the product design without prior authorisation from "MERCOR" SA.
    - Periodic technical inspection and/or maintenance is not carried out per schedule and/or is carried out by unauthorised personnel or service providers not authorised to do so by "MERCOR" SA and/or the equipment has not been properly operated.
    - Unauthorised personnel attempts any intervention in the product outside of the normal operation and maintenance of this equipment.
  13. Any circumstances listed in Item 10 will relieve "MERCOR" SA from the obligation of surety.

*The relevant provisions of the Polish Civil Code shall apply to all matters not regulated in these Warranty Terms & Conditions.*